

4

3

2

1

D

D

C

C

B

B

A

A

REVISIONS

| | | | |
|--------------|------------|-----------|-----|
| REV | DATE: | APPROVED: | ECO |
| 1 | 2012/01/25 | JW | . |
| DESCRIPTION: | | | |
| REV | DATE: | APPROVED: | ECO |
| . | . | . | . |
| DESCRIPTION: | | | |

NOTES: (UNLESS OTHERWISE SPECIFIED):

- 1. MATERIAL: DRAWING ALSO SUITABLE FOR 805U-E.

UNLESS OTHERWISE SPECIFIED
DIMENSIONS ARE IN MILLIMETERS
DO NOT SCALE DRAWING
DRAWING DIMENSIONS ARE INTENDED
TO BE USED AS A GUIDE TO INSTALLATION ONLY
FOR REFERENCE PURPOSES ONLY

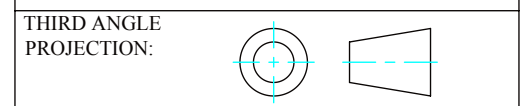

THESE DESIGNS AND SPECIFICATIONS ARE THE
PROPERTY OF COOPER BUSSMANN AND SHALL
NOT BE COPIED OR USED FOR MANUFACTURING
WITHOUT ITS WRITTEN CONSENT.

CHECKED: DATE:

DRAWN: DATE:

DESIGNED: DATE:



| | | | |
|------------|--------------|--------|--------|
| TITLE: | 905U-E | REV | 1 |
| PART #: | . | SIZE | B |
| DRAWING #: | dim_905E_1.2 | SCALE: | 1 : 2 |
| SCALE: | 1 : 2 | SHEET: | 1 OF 1 |

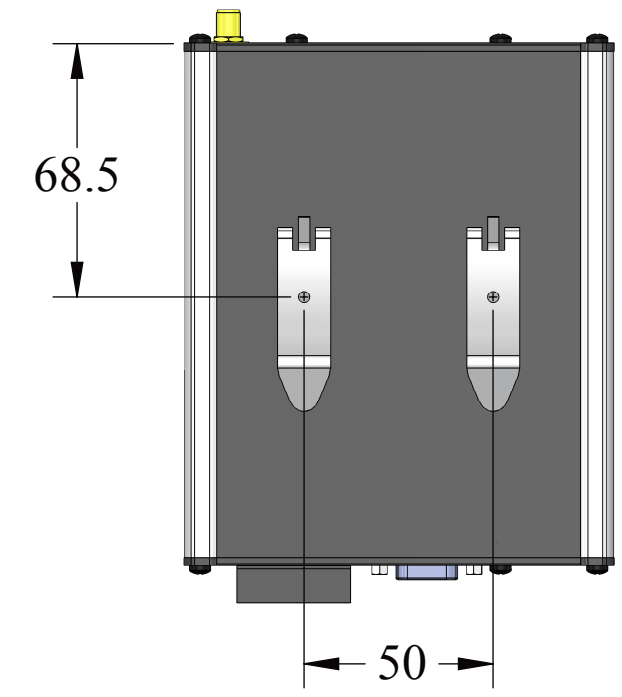
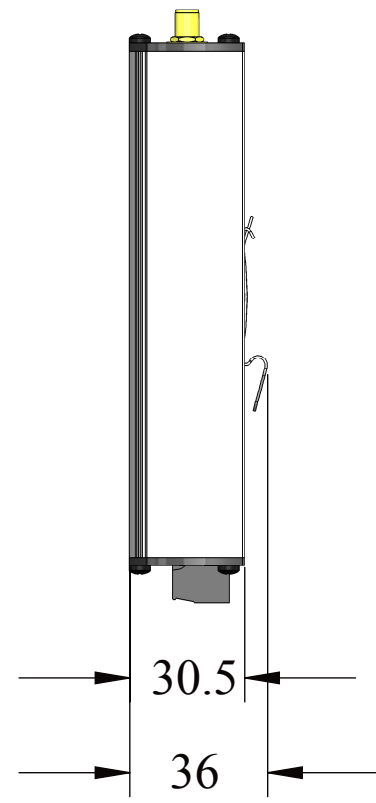
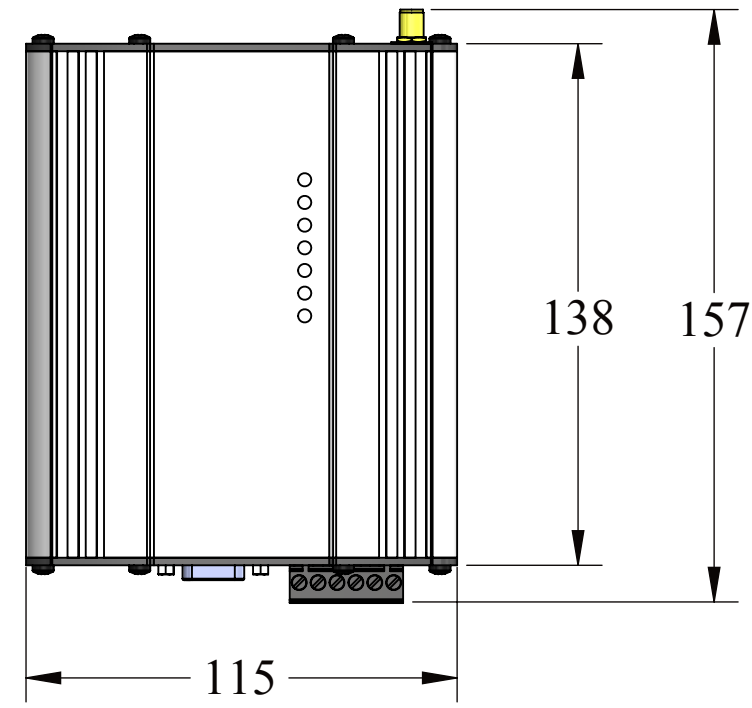
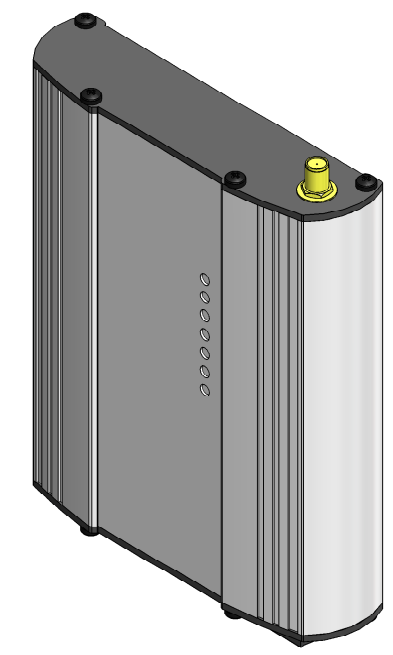

4

3

2

1