

EL-915U-2 USER MANUAL

Version 1.2.4– Feb-2025



915U-2 Wireless Mesh I/O & Gateway



ATTENTION!

Incorrect termination of supply wires may cause internal damage and will void the warranty. To ensure that your 915U-2 Wireless Mesh I/O and Gateway enjoys a long life, check this user manual to verify that all connections are terminated correctly before turning on power for the first time.

CAUTION

To comply with FCC RF exposure requirements in section 1.1310 of the FCC rules, antennas used with this device must be installed to provide a separation distance of at least 20 cm from all persons to satisfy RF exposure compliance.

AVOID

- Operating the transmitter when anyone is within 20 cm of the antenna
- Operating the transmitter before ensuring that all RF connectors are secure and all open connectors are properly terminated
- Operating the equipment near electrical blasting caps or within an explosive atmosphere



NOTE All equipment must be properly grounded for safe operations. All equipment should be serviced only by a qualified technician.

Safety Notice

Exposure to RF energy is an important safety consideration. The FCC has adopted a safety standard for human exposure to radio frequency electromagnetic energy emitted by FCC regulated equipment as a result of its actions in Docket 93-62 and OET Bulletin 65 Edition 97-01.

GNU Free Documentation License

Copyright (C) 2023 ELPRO Technologies.

ELPRO Technologies is using a part of the Free Software code under the GNU General Public License in operating the 915U-2 product. This General Public License applies to most of the Free Software Foundation's code and to any other program whose authors committed by using it. The Free Software is copyrighted by Free Software Foundation, Inc., and the program is licensed "as is" without a warranty of any kind. Users are free to contact ELPRO Technologies at the following Email Address: sales@elprotech.com for instructions on how to obtain the source code used for the 915U-2.

A copy of the license is included in GNU Free Document License at the end of the manual.

Industry Canada

This Class [A] digital apparatus complies with Canadian ICES-003.

This device complies with Industry Canada license-exempt RSS standard(s). Operation is subject to the following two conditions:

- This device may not cause interference, and
- This device must accept any interference, including interference that may cause undesired operation.

This radio transmitter has been approved by Industry Canada to operate with the antenna types listed below with the maximum permissible gain and required antenna impedance for each antenna type indicated. Antenna types not included in this list that have a gain greater than the maximum gain indicated for that type are strictly prohibited for use with this device.

Manufacturer	Model Number	Coax Kit	Net
ELPRO	SG-900-6	CC10/900	5 dB Gain
ELPRO	SG-900-6	CC20/900	2 dB Gain
ELPRO	SG-900EL	CC10/900	2 dB Gain
ELPRO	SG-900EL	CC20/900	-1 dB Loss
ELPRO	YU6/900	CC20/900	4 dB Gain
ELPRO	CFD890EL	Includes 5m Cellfoil	Unity Gain
ELPRO	DG900-1	Includes 1m Cellfoil	-2 dB Loss
ELPRO	DG900-5	Includes 5m Cellfoil	-3 dB Loss

FCC Notice

The 915U-2 module complies with Part 15.247 of the FCC rules.

Operation is subject to the following two conditions:

- This device may not cause harmful interference, and
- This device must accept any interference received, including interference that may cause undesired operation.

The 915U-2 module must be installed in a suitable enclosure that provides mechanical, shock, and fire hazard protection. This device must be operated as supplied by ELPRO. Any changes or modifications made to the device without the written consent of ELPRO may void the user's authority to operate the device.

This device must be installed by professional installers, in compliance with 47 CFR Part 15 Subpart C Section 15.203 and 15.205, who will be responsible for maintaining EIRP no greater than 36 dBm, in accordance with 47 CFR Part 15 Subpart C Section 15.247 (b)(2)(4).

In accordance with 47 CFR Part 15 Subpart C Section 15.203, only the following antenna/coax cable kits combinations can be used.

Manufacturer	Model Number	Coax Kit	Net
ELPRO	SG-900-6	CC10/900	5 dB Gain
ELPRO	SG-900-6	CC20/900	2 dB Gain
ELPRO	SG-900EL	CC10/900	2 dB Gain
ELPRO	SG-900EL	CC20/900	-1 dB Loss
ELPRO	YU6/900	CC20/900	4 dB Gain
ELPRO	CFD890EL	Includes 5m Cellfoil	Unity Gain
ELPRO	DG900-1	Includes 1m Cellfoil	-2 dB Loss
ELPRO	DG900-5	Includes 5m Cellfoil	-3 dB Loss

Part 15—This device has been tested and found to comply with the limits for a Class B digital device, pursuant to Part 15 of the FCC rules (Code of Federal Regulations 47CFR Part 15). Operation is subject to the condition that this device does not cause harmful interference.



NOTE Any changes or modifications not expressly approved by ELPRO may void the users authority to operate this device. This device should only be connected to PCs that are covered by either FCC DoC or are FCC certified.

Hazardous Location Notices



This device complies with 2014/34/EC – ATEX Directive Ex ec IIC T4 Gc, $-40^{\circ}\text{C} \leq T_a \leq +60^{\circ}\text{C}$.

- IEC/EN 60079-0:2007
- IEC/EN 60079-7:2015

WARNING: EXPLOSION HAZARD

Do not disconnect equipment unless power has been switched off or the area is known to be non-hazardous.



This equipment is suitable for use in Class I, Division 2, Groups A, B, C and D; Tamb -40°C to $+60^{\circ}\text{C}$ or non-hazardous locations only.

This equipment shall only be installed in locations meeting Pollution degree 2, and shall be installed according to installation category 2. The maximum altitude of the installation is not to exceed 2000m

This equipment shall be installed in accordance with the requirements specified in Article 820 of the National Electrical Code (NEC), ANSI/NFPA 70-2011. Section 820-40 of the NEC provides guidelines for proper grounding, and in particular specifies that the antenna ground (shield) shall be connected to the grounding system of the building, as close to the point of cable entry as practical.

This equipment shall be installed in a Restricted Access Location (such as a dedicated equipment room or service closet).

The earthing/grounding terminal of the equipment shall be connected to earth ground in the equipment installation.

The external power supply installed with this equipment shall be a Listed, Class 2 power supply, with a rated output between 15 Vdc and 30 Vdc, and min. 2500 mA.



IECEX LC XX.XXXXX

Ex Ec IIC Gc

15-30VDC, 2500mA, IP20

$-40^{\circ}\text{C} \leq T_a \leq +60^{\circ}\text{C}$

Important Notice

ELPRO products are designed to be used in industrial environments by experienced industrial engineering personnel with adequate knowledge of safety design considerations.

ELPRO radio products are used on unprotected license-free radio bands with radio noise and interference. The products are designed to operate in the presence of noise and interference, but in an extreme case radio noise and interference can cause product operation delays or operation failure. Like all industrial electronic products, ELPRO products can fail in a variety of modes due to misuse, age, or malfunction. We recommend that users and designers design systems using design techniques intended to prevent personal injury or damage during product operation, and provide failure tolerant systems to prevent personal injury or damage in the event of product failure. Designers must warn users of the equipment or systems if adequate protection against failure has not been included in the system design. Designers must include this Important Notice in operating procedures and system manuals.

These products should not be used in non-industrial applications, or life-support systems, without consulting ELPRO first.

A radio license is not required in some countries, provided the module is installed using the aerial and equipment configuration described in the 915U-2 Installation Guide. Check with your local distributor for additional information on regulations.

Operation is authorized by the radio frequency regulatory authority in your country on a non-protection basis. Although all care is taken in the design of these units, there is no responsibility taken for sources of external interference. Systems should be designed to be tolerant of these operational delays.

To avoid the risk of electrocution, the aerial, aerial cable, serial cables and all terminals of the 915U-2 module should be electrically protected. To provide maximum surge and lightning protection, the module should be connected to a suitable ground and the aerial, aerial cable, serial cables and the module should be installed as recommended in the 915U-2 Installation Guide

To avoid accidents during maintenance or adjustment of remotely controlled equipment, all equipment should be first disconnected from the 915U-2 module during these adjustments. Equipment should carry clear markings to

indicate remote or automatic operation. For example: "This equipment is remotely controlled and may start without warning. Isolate at the switchboard before attempting adjustments."

The 915U-2 module is not suitable for use in explosive environments without additional protection.

The 915U-2 operates unlicensed radio frequencies and proprietary protocols to communicate over the radio. Nevertheless, if your system is not adequately secured, third parties may be able to gain access to your data or gain control of your equipment via the radio link. Before deploying a system, make sure that you have carefully considered the security aspects of your installation.

Release Notice

This is the December 2013 release of the 915U-2 Wireless Mesh I/O and Gateway User Manual version 1.2.3, which applies to version 1.2.2 and later firmware.

Follow Instructions

Read this entire manual and all other publications pertaining to the work to be performed before installing, operating, or servicing this equipment. Practice all plant and safety instructions and precautions. Failure to follow the instructions can cause personal injury and/or property damage.

Proper Use

Any unauthorized modifications to or use of this equipment outside its specified mechanical, electrical, or other operating limits may cause personal injury and/or property damage, including damage to the equipment. Any such unauthorized modifications: (1) constitute "misuse" and/or "negligence" within the meaning of the product warranty, thereby excluding warranty coverage for any resulting damage; and (2) invalidate product certifications or listings.

CONTENTS

Chapter 1 - INTRODUCTION	8	Dual Band Operation.....	29
1.1 Overview	8	Radio Path Reliability.....	29
1.2 Module Structure.....	9	Design for Failures	30
1.3 Getting Started	10	Indicating a Communications Problem.....	30
Chapter 2 - INSTALLATION	11	WIBNet Communication Registers.....	31
2.1 General.....	11	Testing and Commissioning.....	31
2.2 Power/Supply	11	3.4 WIBMesh	31
Requirements	11	Chapter 4 - CONFIGURATION	32
Expansion I/O Supply	12	4.1 Connecting to the Module	32
Internal I/O	13	4.2 MConfig Utility	34
Grounding	13	Downloading and Installing MConfig	34
2.3 Radio.....	14	Starting MConfig	35
900 MHz Spread Spectrum Radio.....	14	Project Screen.....	36
869 MHz Fixed Frequency Radio	14	Adding Units to a Project	37
Meshing Capability.....	15	Displaying the IP Address List	40
2.4 Antenna	15	Editing Module IP Addresses	41
Dipole and Collinear Antennas	16	Mappings	42
Yagi Antennas	17	Adding or Editing Mapping Parameters	43
2.5 Connections	18	Startup or Force Configuration.....	45
Bottom Panel Connections.....	18	Address Map	46
Ethernet Port.....	18	Common I/O Registers for the 915U-2.....	47
USB Device Port for Configuration.....	18	I/O Configuration.....	47
RS-232 Port	19	Digital Inputs	47
RS-485 port with Modbus Support	19	Digital Outputs.....	48
Side Access Configuration Panel	20	Pulsed Outputs.....	49
Factory Boot Switch	20	Analog Inputs	49
USB Host Port	20	Analog Outputs.....	51
DIP Switches.....	20	Adding Expansion I/O Modules.....	52
Front Panel Connections	21	115S Expansion I/O Memory Map.....	52
Digital or Pulsed Inputs	21	Adding an Expansion I/O to MConfig	53
Digital Outputs (Pulsed Outputs)	22	Fail-safe Blocks	53
Digital Output Fail-safe Status	23	Invalid Register State	55
Analog Inputs.....	23	Sensitivity Blocks.....	55
Differential Current Inputs.....	24	Serial Configuration	56
Voltage Inputs.....	26	Modbus RTU Master.....	57
Analog Outputs.....	26	Serial Expansion I/O.....	58
Chapter 3 - OPERATION	27	Serial Modbus RTU Slave.....	59
3.1 Overview	27	Modbus Configuration	59
3.2 LED Indicators	27	Modbus TCP Server and RTU Slave Tab .	60
Front Panel Indicators.....	27	Modbus TCP Client and RTU Master Tab	61
LED Boot Sequence	27	Adding Mapping Parameters	61
Input and Output Indicators	28	Modbus TCP Mapping Examples.....	62
Digital Inputs.....	28	Modbus RTU Master.....	63
Digital Outputs	28	RS-232/RS-485 Modbus Parameters.....	64
Analog Inputs.....	28	4.3 Web-Based Configuration Utility	65
Analog Outputs	28	Connecting and Logging On.....	65
Ethernet LED Indicators	28	Mesh Parameters	66
3.3 System Design	29	Neighbor RSSI Configuration	67
Radio Channel Capacity.....	29	IP Routing	68

Radio Settings.....	69
Mesh Fixed Routes	70
Module Information Webpage	74
System Tools.....	74
Patch File Firmware Upgrade	75
Full Firmware Upgrade.....	75
Product Reconfiguration.....	78
Feature License Keys.....	78
Chapter 5 - DIAGNOSTICS	80
5.1 IO Diagnostics.....	80
Watchdog Error Log.....	81
Module Information Registers.....	81
Expansion I/O Error Registers.....	81
5.2 Mesh Connectivity.....	82
Link Quality Indicator.....	83
5.3 Mesh Neighbor List.....	83
5.4 Mesh Neighbor RSSI	84
5.5 Mesh Network Diagnostics	85
Ping.....	85
Trace Route.....	85
5.6 Mesh Network Statistics	86
5.7 Monitor Communications	88
Monitor WIBMesh Radio Communications	88
Monitor WIBMesh IP Comms	89
Monitor WIBNet Radio Comms.....	90
5.8 Statistics for WIBMesh and WIBNet	91
Chapter 6 - SPECIFICATIONS	92
Appendix A - DBM TO MW CONVERSION.....	94
Appendix B - I/O STORE REGISTERS	95
Output Coils.....	95
Input Bits.....	95
Input Registers.....	95
Holding Registers	96
Appendix C - EXPANSION I/O REGISTERS	97
I/O Store for 115S-11 Expansion I/O Modules.....	97
I/O Store for 115S-12 Expansion I/O Modules.....	97
I/O Store for 115S-13 Expansion I/O Modules.....	98
Appendix D - MODBUS ERROR CODES	99
Appendix E - PHYSICAL I/O REGISTERS.....	100
115S Serial Expansion Modules I/O Registers.....	101
Appendix F - GNU FREE DOCUMENT LICENSE .	103
Appendix G - OVER-THE-AIR CONFIGURATION .	107
Appendix H - GLOSSARY	110

CHAPTER 1 - INTRODUCTION

1.1 Overview

The 915U-2 Wireless Mesh I/O and Gateway is designed to provide standard off-the-shelf telemetry functions for an economic price. Telemetry is the transmission of data or signals over long distances via radio or twisted-pair wire cable.

Although the 915U-2 module is intended to be simple in its application, it also provides many sophisticated features, which are described in this manual. This manual should be read carefully to ensure that the modules are configured and installed to provide reliable performance.

The 915U-2 module extends the functionality provided by the earlier 105U and 905U-E Series modules. It provides on-board I/O via a front mounting 20-way connector, and has provision for extra expansion modules (ELPRO 115S or Modbus devices), that can be connected using a standard RS-485 serial connection.

The module can monitor the following types of signals:

- Digital (on/off) signals, such as a contact closure or switch
- Analog (continuously variable) signals, such as tank level, motor speed, or temperature
- Pulsed signal, frequency signals, such as metering, accumulated total, or rainfall
- Internal signals, such as supply voltage, supply failure, or battery status

The modules monitor the input signals and transmit the values by radio or Ethernet cabling to another module (or modules) that have been configured to receive this information. The 915U-2 radio is designed to meet the requirements of unlicensed operation for remote monitoring and control of equipment. A radio license is not required for the 915U-2 in many countries.

Input signals that are connected to the module are transmitted and appear as output signals on other modules. A transmission occurs whenever a change of state (COS) occurs on an input signal. A COS of a digital or an internal digital input is a change from "off" to "on," or a change from "on" to "off." For an analog input, internal analog input, or pulse input rate, a COS is a configurable value referred to as sensitivity. The default sensitivity is 1000 counts (3%), but this value can be changed using the Sensitivity Block configuration page in the MConfig Utility, as described in "Sensitivity Blocks" on page 55.

In addition to COS messages, update messages are automatically transmitted on a configurable time basis. These updates ensure system integrity. Pulse inputs counts are accumulated and the total count is transmitted regularly according to the configured update time.

The 915U-2 modules transmit the input/output data using radio or Ethernet. The data frame includes the address of the transmitting module and the receiving module, so that each transmitted message is acted upon only by the correct receiving unit. Each message includes error checking to ensure that no corruption of the data frame has occurred due to noise or interference. The module with the correct receiving address will acknowledge the message with a return transmission (acknowledgment). If the original module does not receive a correct acknowledgment, it will retry up to five times before setting the communications status of that message to "fail." For critical messages, this status can be reflected on an output on the module for alert purposes. The module will continue to try to establish communications and retry each time an update or COS occurs.

The 915U-2 comes from the factory with ELPRO WIBMesh protocol as standard. This protocol provides enhanced features, including IP addressing, and it allows thousands of modules to exist in a system and automatic routing of messages through repeater stations. The module can also be configured with the legacy WIBNet protocol, which provides operation with existing ELPRO wireless I/O devices (905 series and 105 series 869 MHz modules). The module can easily be switched between the two protocol versions by selecting the appropriate protocol from a built-in webpage (see "Product Reconfiguration" on page 78).

A system can be a complex network or a simple pair of modules. An easy-to-use configuration procedure allows you to specify any output destination for each input. Each 915U-2 radio can have up to 24 expansion I/O modules (ELPRO 115S) connected by RS-485 twisted pair cable. Any input signal at any module may be configured to

appear at any output on any module in the entire system.

Modules can be used as repeaters to re-transmit messages on to the destination module. Repeaters can repeat messages on the radio channel or from the radio channel to the serial channel (or serial to radio). The meshing protocol automatically selects other stations to act as repeaters if required (up to ten hops). If you configure the module to use the legacy WIBNet protocol, up to five repeater addresses may be configured for each input-to-output link. For more information about using WIBNet, see “Product Reconfiguration” on page 78.

The units can be configured using the MConfig Utility via Ethernet or USB, or by accessing the internal webpages using a Web browser. The MConfig Utility is described in “4.2 MConfig Utility” on page 34. For Web-based configuration, see “4.3 Web-Based Configuration Utility” on page 65.

1.2 Module Structure

The 915U-2 module is made up of different areas that all interface with a central input and output storage area (I/O store). The I/O store is an area of memory made available for the status of the physical on-board I/O and internal I/O registers. It also provides services for other processes within the module.

The I/O store is split into eight different blocks types:

- Two blocks made available for bit data (discrete)
- Two blocks made available for word data (analog)
- Two blocks made available for 32-bit words data (32-bit analogs)
- Two blocks made available for floating point data (floats)

Each of these block types in turn support input and output locations that can interface with the physical I/O on the local machine and also be used for data storage when used as a gateway to external devices. These block type locations are illustrated in Figure 1 and are described in Appendix B. There are other registers within the database that can be used for system management.

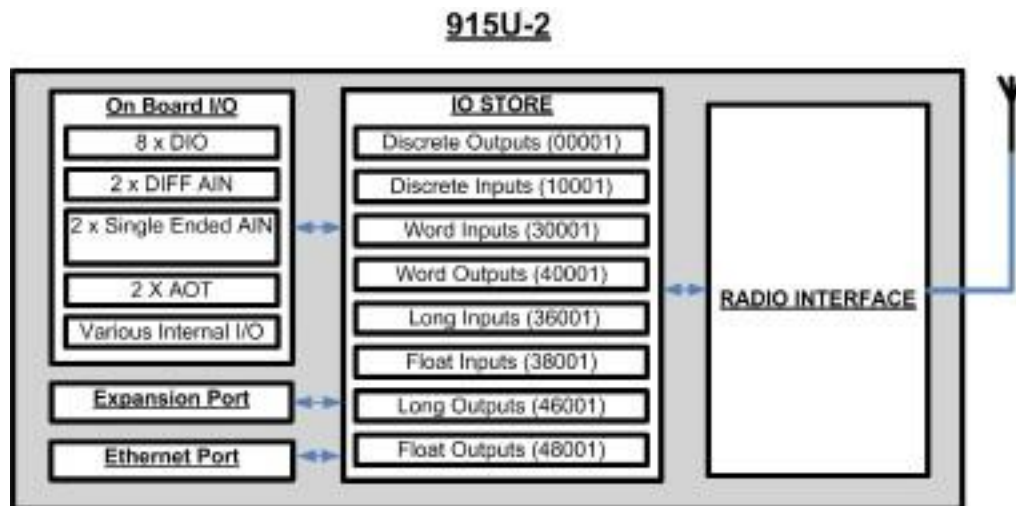

Figure 1 Module Structure

The Radio Interface (see Figure 1) allows the 915U-2 to communicate with other modules within the system using a proprietary radio protocol called WIBMesh. I/O Messages from other 915U-2 modules are received on the radio port and then passed to the I/O store which will in turn update the register locations accordingly. The WIBMesh protocol is designed to provide reliable radio communications on an open license-free radio channel. It is an extremely efficient protocol for radio communications because the messages are sent using exception reporting (only transmitting when there is a change of an input signal) rather than transmitting all of the time. Update messages can also be configured at a predetermined time for integrity checks.

Each message can be comprised of multiple I/O values, referred to as a “block of I/O.” The messages use error checking and return acknowledgment for greater reliability. Up to four attempts are made when transmitting the message over each hop of the radio path, and if no acknowledgment is received a Comms indication can be flagged.

The on-board I/O includes eight discrete I/O, two single-ended analog inputs, two differential analog inputs, and two current sourcing analog outputs. Each discrete I/O can function as either a discrete input (voltage-free contact input) or discrete output (transistor output). Each I/O point is linked to separate I/O registers within the I/O data store.

The following internal I/O can be accessed from the I/O store. The inputs can be used to interpret the status of a single module or an entire system:

- Battery voltage—The battery terminal voltage, displayed as an analog value.
- Loop supply—The +24 Vdc analog loop supply (ALS) used to power analog current loops, displayed as an analog value.
- Expansion module volts—The supply voltage of the connected expansion modules, displayed as an analog value.
- RSSI – The radio signal level for the selectable address, reported as a dB level.
- Comms Fail—A selectable register can indicate a Communications Fail error for a particular message transmission.

The expansion port, allows 115S expansion I/O modules to be added to the module. Expansion I/O is dynamically added to the internal I/O of the 915U-2 module by adding an offset to the address.

1.3 Getting Started

Most applications for the 915U-2 module require little configuration. The 915U-2 has many sophisticated features, but if you do not require these features you can use this section to configure the units quickly.

To get started quickly:

1. Read Chapter 2, which describes the power supply, antenna/coax connections, and I/O connections.
2. Power on the 915U-2 module and set up an Ethernet connection to your PC.
For detailed steps, see “4.1 Connecting to the Module” on page 32.
3. Log on to the module’s Web-based configuration utility and click Network on the menu to display the Network configuration webpage.
For logon instructions, see “4.3 Web-Based Configuration Utility” on page 65.
4. On the Network webpage, configure the Ethernet interface with an IP address that is compatible with your network or PC.
5. Save the configuration.

The 915U-2 module is now ready to use. For further configuration instructions, see Chapter 4.

CHAPTER 2 - INSTALLATION

2.1 General

The 915U-2 Series modules are housed in a plastic enclosure with DIN rail mounting, providing options for up to 14 I/O points, and separate power and communications connectors. The enclosure measures 170 x 150 x 33 mm, including the connectors. The antenna protrudes from the top.

2.2 Power/Supply

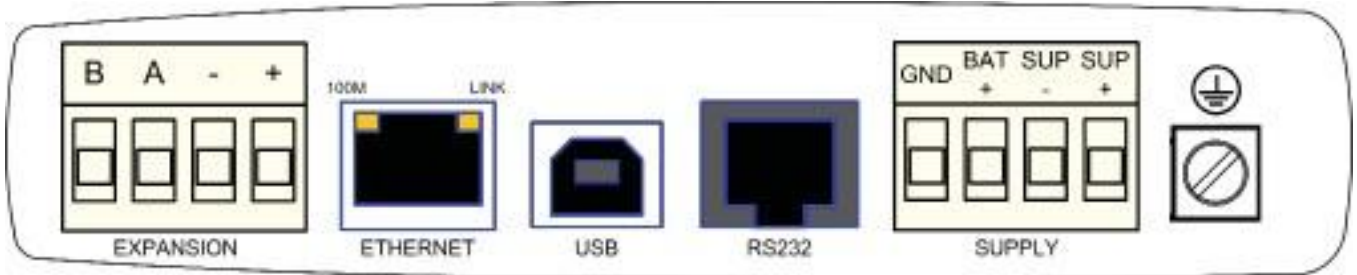

Figure 2 Power Connectors

POWER SUPPLY

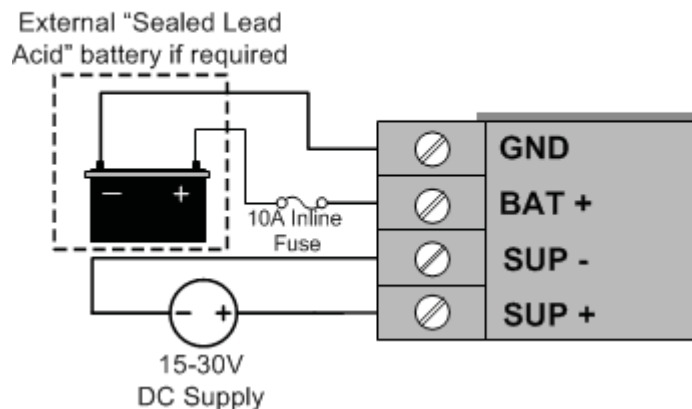

Figure 3 Supply Connections

Requirements

There are two recommended power options available for the 915U-2 module:

- 15–30 Vdc power source rated at 37W, connected to the SUP+ and SUP- terminals
- 12–15 Vdc power source rated at 24W, connected to the BAT+ and GND terminals

A primary power supply connected to the SUP+ and SUP- terminals automatically charges a 13.8V sealed lead-acid battery, if connected to the BAT+ and GND terminals at up to 1A at ambient room temperature (25°C). Battery charge current is reduced to 0.5A at 60°C. If using a battery, it is recommended that a 10A inline fuse be fitted as prevention against battery short circuit.

If you are using the first option and the primary supply fails, the battery supply will continue to power the module without interruption to the operation. The supply and battery charging terminals are hosted on the 4-way connector on the bottom edge of the module labeled “Supply.” Both the supply and battery connections have reverse polarity and over-voltage protection.

The power supply should be CSA Certified Class 2, approved for normal operation. If the device is being used in a Class I Div 2 explosive area, the supply must have Class I Div 2 approval.

When powering the module, the power source must be able to provide sufficient current to power all module operations, including quiescent current, peak transmit current, and digital and analog I/O, including loop supply and battery charging (if applicable). To calculate the power supply current limit, use the following criteria.

Current	@ 13.8V	@ 24V
Quiescent current of the module	200 mA	115 mA
Module maximum I/O (4xAI, 2xAO, 8xDO)	500 mA	290 mA
Peak transmit current	500 mA	290 mA
External expansion I/O	1000 mA	575 mA
Battery charging	N/A	575 mA

The following table shows typical +24V supply current limits with different module options enabled. Transmit current is not added because it is not a constant.

	Expansion I/O	No Expansion I/O
No battery fitted (no charging)	1270 mA	695 mA
Battery fitted	1555 mA	980 mA

The following table shows typical +13.8V supply current limits with different module options enabled. Transmit current is not added because it is not a constant.

	Expansion I/O	No Expansion I/O
Current limit	2200 mA	1200 mA

For example, if a module is powered by a 24 Vdc supply and there is no backup battery connected and it has expansion I/O fitted, the minimum current needed is 1.3A @ 24V (32W). This is allowing for 290 mA peak transmit current and up to 1A for the expansion I/O.

Expansion I/O Supply

To allow increased I/O capacity, a second four-way terminal labeled “Expansion I/O” provides a +12V supply (up to 1A) and RS-485 communications for any 115S serial expansion I/O modules.

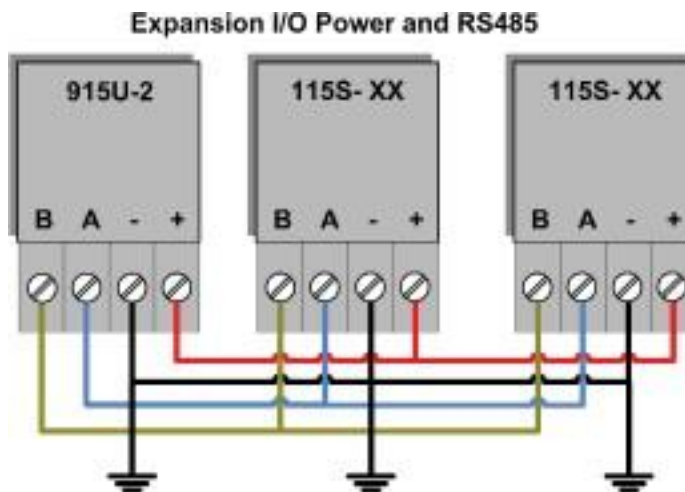

Figure 4 Expansion I/O Power and RS-485

As a guide, when using the I/O power connection from the 915U-2, the number of I/O modules is limited to three 115S-11 (using inputs), or one x 115S-12, or one x 115S-13. If more I/O modules are required, you need to calculate the overall current consumption using the following criteria, and power the modules from an external supply.

- 115S module static current drain = 120 mA
- 115S digital inputs require 13 mA per active input
- 115S digital outputs require 25 mA per active output
- 115S analog inputs and outputs require 50 mA per I/O when operating at 20 mA

For example, a single 115S-11 using inputs only has a current consumption of approximately 320 mA, which means that you can connect up to three 115S-11 modules to the expansion port without overloading the on-board I/O power supply. A single 115S-12 using all analog inputs and digital outputs has a current consumption of approximately 720 mA, so you can only connect one.

Keep in mind that when calculating the current consumption for the expansion I/O, the maximum available current from the on-board power supply is 1A. If the overall expansion I/O current consumption is over the 1A maximum an external power source is required.

Internal I/O

The internal supply voltage register locations shown in the following table can be monitored using the Diagnostics webpage within the module’s Web-based configuration utility (see “5.1 IO Diagnostics” on page 80 for details). The values can also be mapped to a register or an analog output on another module within the radio network.

Register	Description
30005	Local supply voltage (0–40V scaling).
30006	Local 24V loop voltage (0–40V scaling). Internally generated +24V supply used for analog loop supply. Maximum current limit is 100 mA.
30007	Local battery voltage (0–40V scaling).
30008	115S supply voltage (0–40V scaling).
38005–38008	Floating point registers that display the actual supply voltage, battery voltage, +24V supply, and 115S supply. Note that these are actual voltage values, whereas registers 30005–30008 display a number between 16384 and 49152 that represents the voltage scale 0–40V.

To calculate the supply voltages from the register value use the following calculation:

$$\text{Volts} = \frac{(\text{Register Value}) - 8192}{1024}$$

There are no dedicated discrete low voltage alarm indicators. However, each supply voltage does have a high and a low set point status that can be used for this type of alarm. See “Analog Inputs” on page 23 for details on how to configure these alarms.

Grounding

To provide maximum surge and lightning protection each module should be effectively earthed/grounded via a GND terminal on the module. This is to ensure that the surge protection circuits inside the module are effective. The module should be connected to the same common ground point as the enclosure ground and the antenna mast ground.

The 915U-2 has a dedicated earth/ground connection screw on the bottom end plate next to the supply terminals. All earth/ground wiring should be minimum 2 mm² – 14 AWG. If using the 915U-2 with serial expansion I/O modules, all expansion modules must have a separate earth/ground connection from the front terminal back to the common earth or ground point. See Figure 5.

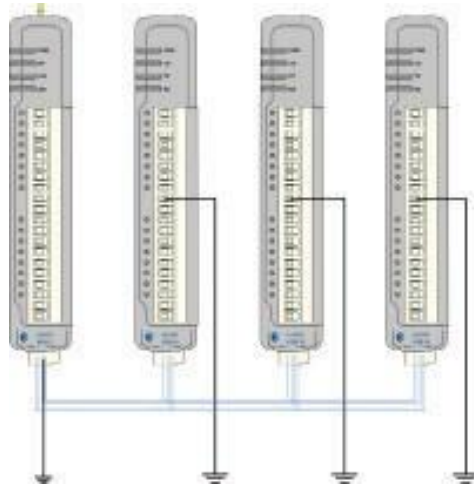

Figure 5 Grounding

2.3 Radio

The following radio variants are available in the 915U-2, depending on the country of operation.

900 MHz Spread Spectrum Radio

The radio uses frequency hopping spread spectrum modulation, which is a method of transmitting radio signals by switching the carrier among many frequency channels using a pseudo-random sequence, called a hopset. There are two hopsets that cycle through the sequence and switch to a different channel after each radio transmission. Each hopset uses a different pseudo-random sequence of 50 channels.

The radio operates in the 902–928 MHz ISM band, which is split into two frequency bands, 902–914 MHz (low) and 915–928 MHz (high). In the United States and Canada, the 915U-2 can use both high and low bands. However, in other countries, such as Australia, only the 915–928 MHz band is available.

Some countries use fewer channels. For example, New Zealand uses 18 channels in the frequency band 922.75–927.00 MHz. In countries that allow the two bands to be used, the frequency band can be changed by using the MConfig Utility and selecting the hopset on the Radio Settings screen for the module. The hopset only displays the frequency bands available for the model and country. For details, see “Radio Settings” on page 69.

The receiver is continually scanning all channels within the hopset, and when a valid data packet is received it locks on to the channel and receives the data.

A spread-spectrum transmission offers the following advantages over a fixed-frequency transmission:

- Spread-spectrum signals are more resistant to narrow-band interference
- Spread-spectrum signals are difficult to intercept or eavesdrop because of the pseudo-random transmission sequences
- Transmissions can share a frequency band with other types of conventional transmissions with minimal interference

869 MHz Fixed Frequency Radio

The 869 MHz fixed frequency radio operates in the unlicensed fixed frequency band of 869 MHz and is used in Europe. There are two frequencies. The first operates at 869.525 MHz with a maximum transmit power level of 500 mW, and is regulated with a 10% duty cycle on the channel. This duty cycle limit requires that the module not transmit for more than 10 % of the total operating time, which means other users of the unlicensed frequency are able to transmit without interference. The second frequency operates at 869.875 MHz with a transmit power level of 5 mW and no duty cycle regulation on the channel, which means the module can freely transmit as often as is needed.

 **NOTE** Care must be taken to ensure that the duty cycle limit is not exceeded when using the 869.525 MHz frequency.

Meshing Capability

The ELPRO WIBMesh protocol is based on the Ad hoc On Demand Distance Vector (AODV) routing algorithm, which is a routing protocol designed for ad hoc networks. AODV is capable of unicast routing and is an on-demand algorithm, meaning that it builds and maintains these routes only as long as they are needed by the source devices. The AODV protocol creates a table that shows the connection routes to other device in the system. The protocol uses sequence numbers to ensure that the routes are kept as current as possible. It is loop-free and self-starting, and can scale to a large numbers of nodes. See “3.4 WIBMesh” for configuration details.

2.4 Antenna

The 915U-2 module operates reliably over large distances. The distance that can be reliably achieved varies with each application and depends on the type and location of antennas, the degree of radio interference, and obstructions to the radio path (such as hills or trees). Typical reliable distances are detailed below. However, longer distances can be achieved if antennas are mounted in elevated locations, such as on a hill or on a radio mast.

Using the 900-MHz spread spectrum radio, the distances achievable are as follows:

- USA/Canada: 15 miles, 6-dB net gain antenna configuration permitted (4W EIRP)
- Australia/NZ: 12 km, unity gain antenna configuration (1W EIRP)

To achieve the maximum transmission distance, the antennas should be raised above intermediate obstructions so that the radio path is a true line-of-sight path. Because of the curvature of the earth, the antennas need to be elevated at least 15 feet (5m) above ground for paths greater than 3 miles (5 km). The modules will operate reliably with some obstruction of the radio path, although the reliable distance is reduced. Obstructions that are close to either antenna have a greater blocking effect than obstructions in the middle of the radio path. For example, a group of trees around the antenna is a larger obstruction than a group of trees further away from the antenna.

Maximum Gain per Region		
Country	Max Gain (dB)	
USA / Canada	6	
Australia / New Zealand	0	
Europe	0	
Typical Antenna Gains		
Part No	Antenna	Gain (dB)
DG900	Whip with 15' (5m) cable	-2
CFD890EL	Dipole with 15' (5m) cable	0
SG900-EL	5 dBi Collinear (3 dBd)	5
SG900-6	8 dBi Collinear (6 dBd)	8
YU6-900	6 element Yagi	10
YU16-900	16 element Yagi	15
Typical Coax Losses (900 MHz)		
CC3-SMA	10' (3m) Cellfoil Coax	-1 dB
CC10-SMA	33' (10m) Cellfoil Coax	-3 dB
CC20-SMA	66' (20m) Cellfoil Coax	-6 dB

The 915U-2 module provides a range of test features, including displaying the radio signal strength. Line-of-sight paths are only necessary to obtain the maximum range. Obstructions reduce the range but may not prevent a reliable path. A larger amount of obstruction can be tolerated for shorter distances. For very short distances, it is possible to mount the antennas inside buildings. All radio paths require testing to determine if they are reliable (see “5.6 Mesh Network Statistics” on page 86). Where it is not possible to achieve reliable communications between two modules, a third module may be used to receive the message and re-transmit it. This module is referred to as a repeater, and it may also have input and output (I/O) signals connected to it, and may form part of the I/O network. See “1.1 Overview” on page 8.

An antenna should be connected to the module via 50-ohm coaxial cable (such as RG58, RG213, or Cellfoil), and terminated with a male SMA coaxial connector. The higher the antenna is mounted, the greater the transmission range. However, as the length of the coaxial cable increases, so do cable losses. For use on unlicensed frequency channels, there are several types of suitable antennas. It is important to choose antennas carefully in order to avoid contravening the maximum power limit on the unlicensed channel. If in doubt, contact your distributor.

The net gain of an antenna and cable configuration is the gain of the antenna (in dBi) less the loss in the coaxial cable (in dB). The net gain of the antenna and cable configuration is determined by adding the antenna gain and the cable loss. For example, a six-element Yagi with 70 feet (20m) of Cellfoil cable has a net gain of 4 dB (10–6 dB).

Connections between the antenna and coaxial cable should be carefully taped to prevent ingress of moisture. Moisture ingress in the coaxial cable is a common cause for problems with radio systems because it greatly increases radio losses. We recommend that the connection be taped—first with a layer of PVC tape, next with a vulcanizing tape (such as 3M™ 23 tape”), and finally with another layer of PVC UV-stabilized insulating tape. The first layer of tape allows the joint to be easily inspected when troubleshooting because the vulcanizing seal can be easily removed.

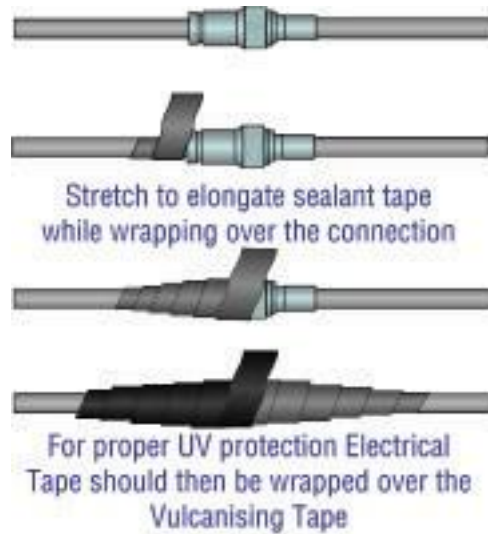

Figure 6 Wrapping Coaxial Connections

Where antennas are mounted on elevated masts, the masts should be effectively earthed/grounded to avoid lightning surges. For high lightning risk areas, surge suppression devices between the module and the antenna are recommended. If the antenna is not already shielded from lightning strike via an adjacent earthed/grounded structure, a lightning rod may be installed above the antenna to provide shielding.

Dipole and Collinear Antennas

Collinear antennas transmit the same amount of radio power in all directions, and are easy to install and use because they do not need to be aligned to the destination. The dipole antenna with integral 15 ft cable does not require an additional coaxial cable. However, a cable must be used with collinear antennas. In order to obtain the maximum range, collinear and dipole antennas should be mounted vertically, preferably one wavelength away from a wall or mast.

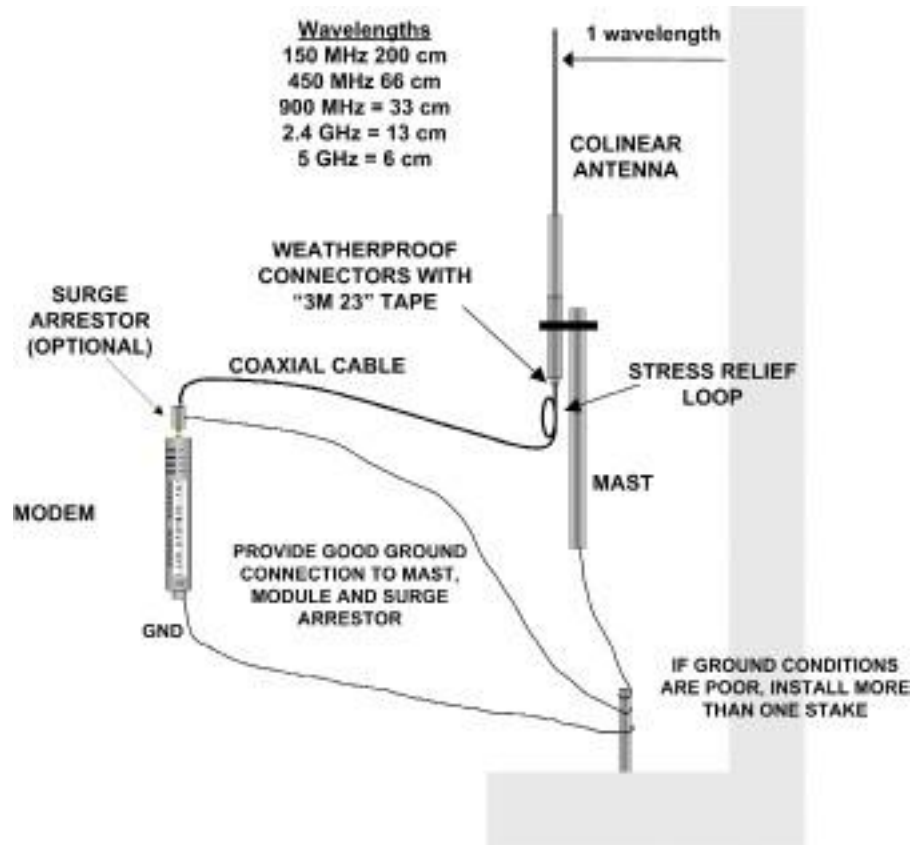

Figure 7 Collinear Antenna Mounting

Yagi Antennas

Yagi antennas provide high gain in the forward direction, but lower gain in other directions. They may be used to compensate for coaxial cable loss for installations with marginal radio path. The Yagi gain also acts on the receiver, so that adding Yagi antennas at both ends of a link provides a double improvement.

Yagi antennas are directional. That is, they have positive gain to the front of the antenna, but negative gain in other directions. Therefore, Yagi antennas should be installed with the central beam horizontal and must be pointed precisely in the direction of transmission to benefit from the gain of the antenna. The Yagi antennas may be installed with the elements in a vertical plane (vertically polarized) or in a horizontal plane (horizontally polarized). However, both antennae must be in the same plane for maximum signal strength. If the antennae are mounted in different planes the receive signal level is reduced by approximately 30 dB.



Figure 8 Yagi Antenna Mounting

For a two-station installation with both modules using Yagi antennas, horizontal polarization is recommended. If there are more than two stations transmitting to a common station, the Yagi antennas should have vertical polarization, and the common or central station should have a collinear (non-directional) antenna.

! NOTE Yagi antennas normally have a drain hole on the folded element. The drain hole should be located on the bottom of the installed antenna.

2.5 Connections

Bottom Panel Connections

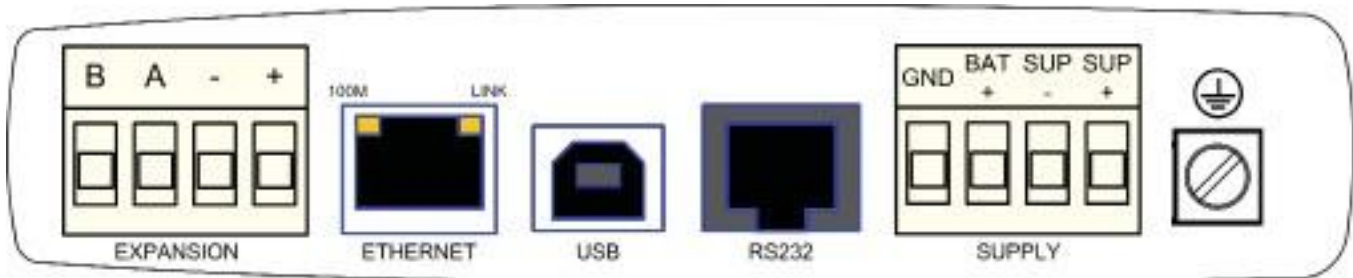

Figure 9 Bottom Panel Connections

Ethernet Port

The 915U-2 module provides a standard RJ-45 Ethernet port compliant to IEEE 802.3 10/100BaseT. This port provides full access to the module, including configuration, diagnostics, log file download, and firmware upload of both the local and remote units. Additionally, the Ethernet port can provide network connectivity for locally connected third-party devices with Ethernet functionality.

USB Device Port for Configuration

The 915U-2 module also provides a USB device (USB-B) connector. This connector provides configuration of the device and remote configuration access to other devices in the radio network.

RS-232 Port

The 915U-2 module provides an RS-232 serial port that supports operation at data rates up to 230,400 baud. This port supports Modbus protocol. The RS-232 port is provided by an RJ-45 connector wired as a DCE according to the EIA-562 Electrical Standard.

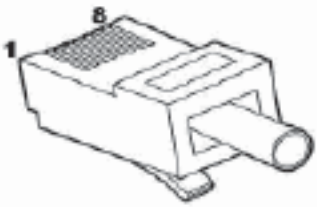
RJ-45	Signal	Required	Signal name	Connector
1	RI		Ring Indicator	
2	DCD		Data Carrier Detect	
3	DTR	Y	Data Terminal Ready	
4	GND	Y	Signal Common	
5	RXD	Y	Receive Data (from 915U-2)	
6	TXD	Y	Transmit Data (to 915U-2)	
7	CTS		Clear to Send	
8	RTS		Request to Send	

RS-485 port with Modbus Support

The 915U-2 module provides an RS-485 serial port that supports operations at data rates up to 230,400 baud. The default baud rate is 9600 baud, no parity, 8 data bits and 1 stop bit, which matches the 115S serial expansion module defaults. This port supports the Modbus protocol.

The RS-485 port terminal is hosted on the four-way expansion connector on the bottom edge of the module. An on-board RS-485 termination resistor provides line attenuation for long runs. As a general rule, termination resistors should be placed at each end of the RS-485 cable. When using 115S expansion I/O modules, remember to enable the RS-485 termination resistor switch that is located on the end module.

Expansion I/O Power and RS485 serial connection

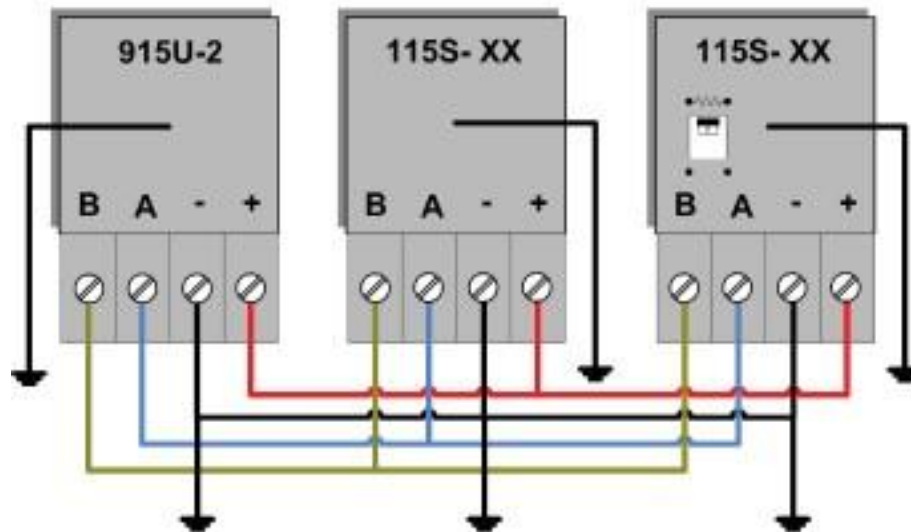

Figure 10 RS-485 Connections

Side Access Configuration Panel

A small access panel on the side of the module hides a factory boot switch, USB host port, and a small bank of DIP switches that are used for analog input voltage and current selection, external boot, and default configuration settings.

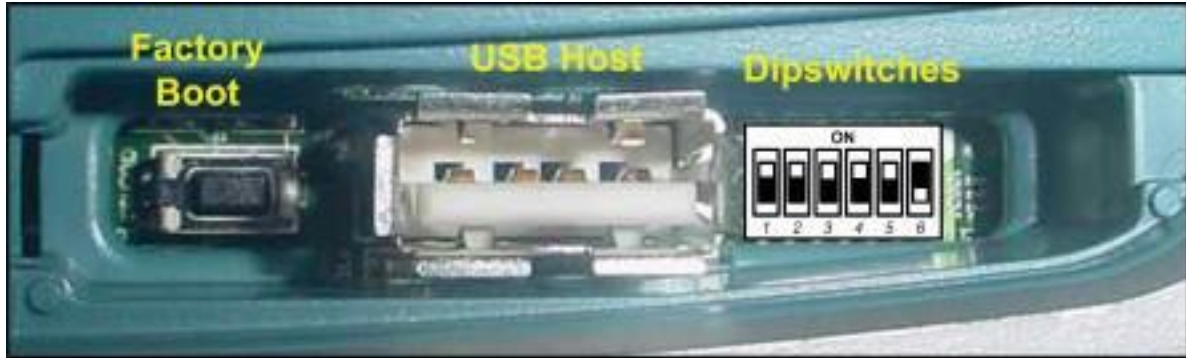

Figure 11 Access Panel

Factory Boot Switch

The factory boot switch is used for factory setup and diagnostics. This switch should only be used if advised by ELPRO technical support.

USB Host Port

This port is a USB host (master port) that can interface with USB storage devices for upgrading the module firmware. For details, see “System Tools” on page 74.

DIP Switches

The DIP switches are used to select a number of functions within the module, as shown in the following table.

- DIP switches 1 to 2—Used for measuring current or voltage on analog input 3. Set DIP switches to “on” to measure current (0–20 mA) and “off” for voltage (0–5 Vdc).
- DIP switches 3 to 4—Used for measuring current or voltage on analog input 4. Set DIP switches to “on” to measure current (0–20 mA) and “off” for voltage (0–5 Vdc).
- DIP switch 5—Not used.
- DIP switch 6—When set to “on” (enabled) and the module is restarted, the module boots up with a known factory default configuration, including a default IP address for the Ethernet connection. See “4.1 Connecting to the Module” on page 32.

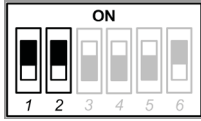
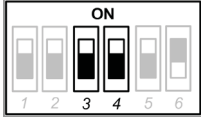
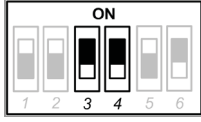
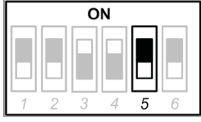
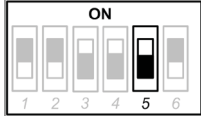
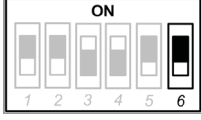
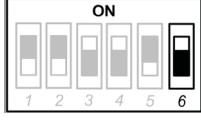

NOTE When DIP switch 6 is “on,” radio and I/O functionality is disabled.

Switch	Function	Current	Voltage
DIP 1 and 2	Analog Input 3		
DIP 3 and 4	Analog Input 4		
Switch	Function	Disabled	Enabled
DIP 5	Not used		
DIP 6	Setup Mode		

Front Panel Connections

The front panel on the 915U-2 module provides connections for the following:

- Eight digital input/output (DIO 1–8)
- Two 12-bit, 0.1% accuracy differential analog inputs
- Two single-ended 12-bit, 0.1% accuracy analog inputs
- Two 13-bit, 0.1% accuracy current sourcing analog outputs
- Connection terminals for common and +24V analog loop supply (ALS); maximum ALS current limit is 100 mA

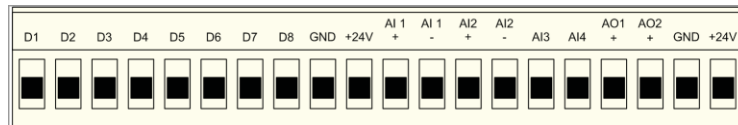

Figure 12 Front Panel Connections

Digital or Pulsed Inputs

Each digital I/O channel on the 915U-2 module can act as either an input or an output. The input/output direction is automatically determined by the connections and configuration of the I/O. If you have an I/O channel wired as an input but operate the channel as an output, no electrical damage will occur but the I/O system will not operate correctly. For example, if you are operating the channel as an output and performing a read inputs on this location, it will indicate the status of the output.

Marked D1–8, the digital inputs share the same terminals as the digital outputs on the 915U-2 module. A digital input is activated by connecting the input terminal to GND or common, either by voltage-free contact, TTL level, or transistor switch. Each digital input has an orange indication LED that will turn on when the input has been connected to a GND.

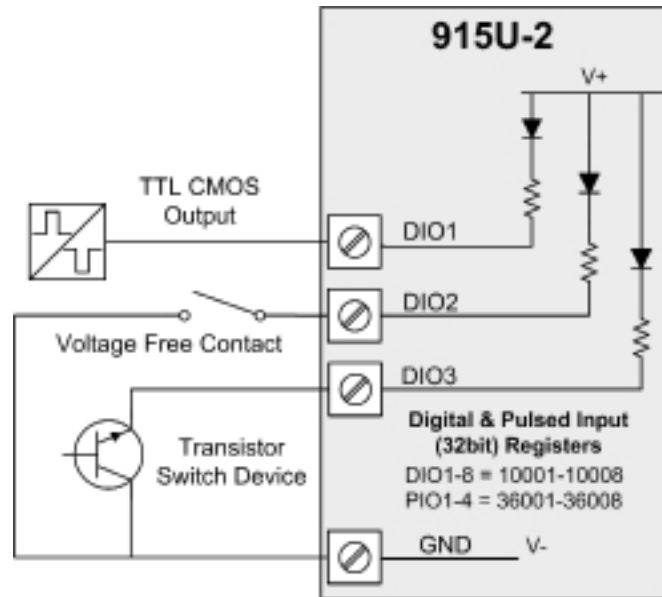

Figure 13 Digital/Pulsed Input Wiring

Digital inputs 1–4 can be used as pulsed inputs. The maximum pulse frequency is 50 kHz for input 1 and 2, and 1 kHz for input 3 and 4. Digital/pulsed inputs are suitable for TTL signal level, NPN-transistor switch devices, or voltage-free contacts (a relay or switch with debounce capacitor).

Frequencies greater than 1 kHz need to use a TTL logic drive or an external pull-up resistor (1KΩ to V+). Pulsed inputs are converted to two different values internally. The first value is the pulse count, which is an indication of how many times the input has changed state over a configured time period. The second value is a pulse rate, which is an analog input derived from the pulse frequency. For example, 0 Hz = 4 mA and 1 kHz = 20 mA.

All pulsed input counts are stored in non-volatile RAM, so that the values are saved in the event of a power failure or a module reset.

Digital Outputs (Pulsed Outputs)

Digital outputs are open-collector transistors, and are able to switch loads up to 30 Vdc, 200 mA. The eight digital outputs share the same terminals as the digital input. These terminals are marked D1–8.

Digital/Pulsed Output

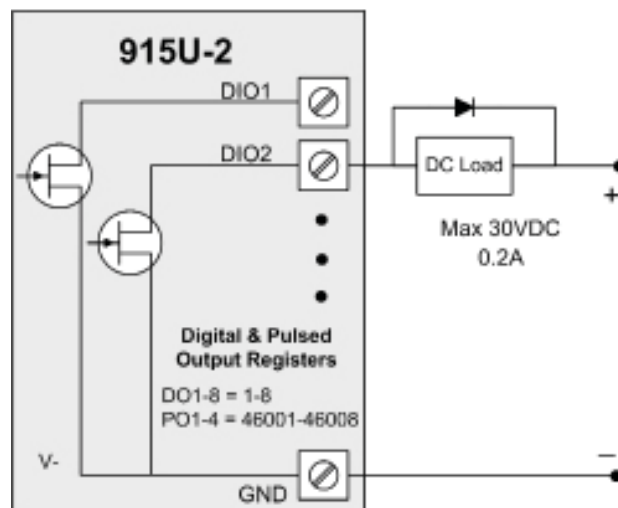

Figure 14 Digital Output Wiring

When active, the digital outputs provide a transistor switch to EARTH (Common). To connect a digital output, see Figure 14. A bypass diode (IN4004) is recommended to protect against switching surges for inductive loads such as relay coils. The digital channels D1–4 on the 915U-2 module can be used as pulse outputs with a maximum output frequency of 10 kHz.

Digital Output Fail-safe Status

In addition to indicating the digital output status (on or off), the LEDs can also indicate a communications failure by flashing the output LED. This feature can be used by configuring a fail-safe time and status via the I/O Digital Output screen in the MConfig Utility (see “I/O Configuration” on page 47.)

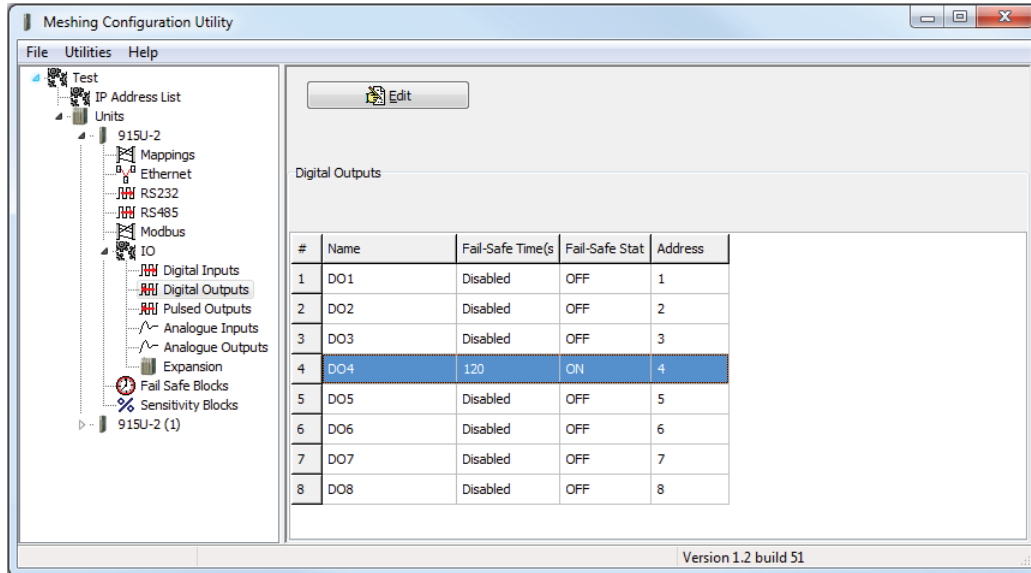

Figure 15 Digital Output Fail-safe Times

The fail-safe time is the time the output counts down before activating a fail-safe state. Normally this would be configured for a little more than twice the update time of the mapping that is sending data to it. This is because the fail-safe timer is restarted whenever it receives an update. If you send two successive updates and fail to receive both of these messages, the timer counts down to zero and activates the fail-safe state.

If the fail-safe state is enabled (on), the LED flashes briefly off and the digital output turns on. If the fail-safe state is disabled (off), the LED flashes briefly on and the digital output turns off.

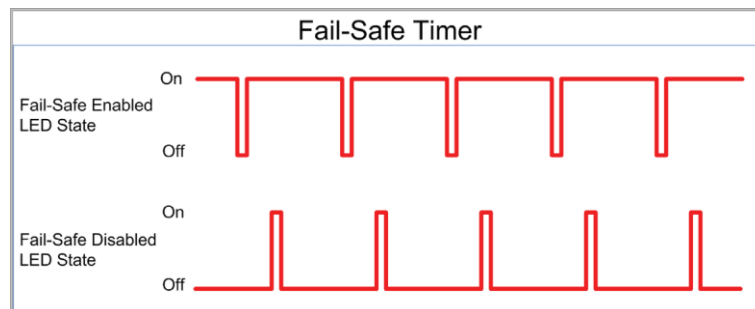

Figure 16 Fail-Safe State

Analog Inputs

The 915U-2 module provides two floating differential analog inputs and two grounded single-ended analog inputs. Analog inputs 1 and 2 will automatically measure current (0–20 mA) or voltage (0–25V), depending on what is connected to the input. Analog inputs 3 and 4 must be configured to measure current (0–20 mA) or voltage (0–5V) via the DIP switches on the configuration panel (see “Side Access Configuration Panel” on page 20).

An internal 24V analog loop supply (ALS) provides power for any current loops with a maximum current limit of 100 mA. The LEDs have an analog diagnostic function and will indicate the status of the input. If the current is less than 3.5 mA, the LED is off. If the current is greater than 20.5 mA, the LED is on. The LED will flicker with the duty cycle relative to the analog reading in this range.

NOTE By default, there is a five-second delay on the input because of the filter. Filter times can be changed using the Analog Input screen within the MConfig Utility. For more information, see “Analog Inputs” on page 23.

The LEDs next to AI1+, AI2+ flash according to the current on these inputs. The LEDs next to AI1- and AI2 flash according to the voltage on the analog inputs.

Differential Current Inputs

Only analog input 1 and 2 can be wired as differential Inputs. Differential mode current inputs should be used when measuring a current loop, which cannot be connected to ground. This allows the input to be connected anywhere in the current loop. Common mode voltage can be up to 27 Vdc.

Figure 17 indicates how to connect loop-powered or externally powered devices to the 915U-2 differential analog inputs. It should also be noted that the differential inputs can also be used to connect single-ended current sinking or current sourcing devices. Figure 19 shows how to connect to these types of devices.

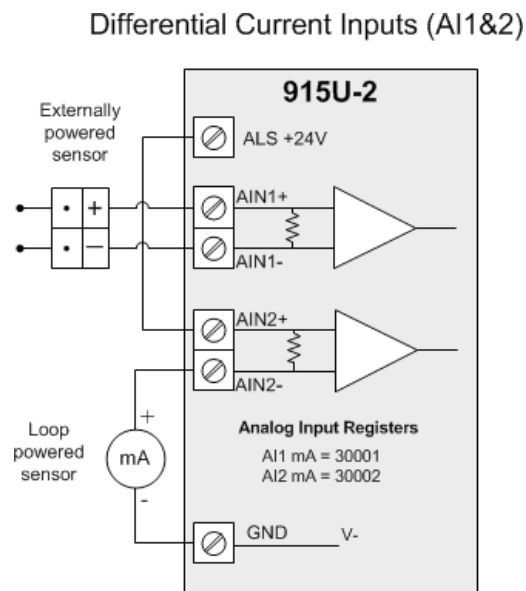
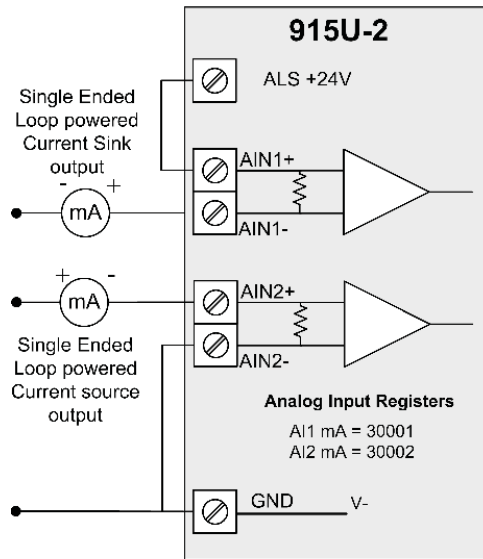

Figure 17 Differential Current Inputs

***Single Ended Current Inputs (AI1&2)**



Each differential input can also be used to connect single-ended current sinking or sourcing devices.

Figure 18 AI 1 & 2 Single-ended Current Inputs

Single-ended current input mode is useful if the sensor loop is grounded to the 915U-2 module. Devices can be powered from the 24V analog loop supply (ALS) generated internally from the module.

The DIP switches (located in the side access panel) are used to determine if the inputs will be current or voltage. DIP switches 1 and 2 are used for analog 3, and DIP switches 3 and 4 are used for analog 4. For current, set both DIP switches to the “on” position. For voltage, set both to “off.”

Single Ended Current Input (AI3&4)

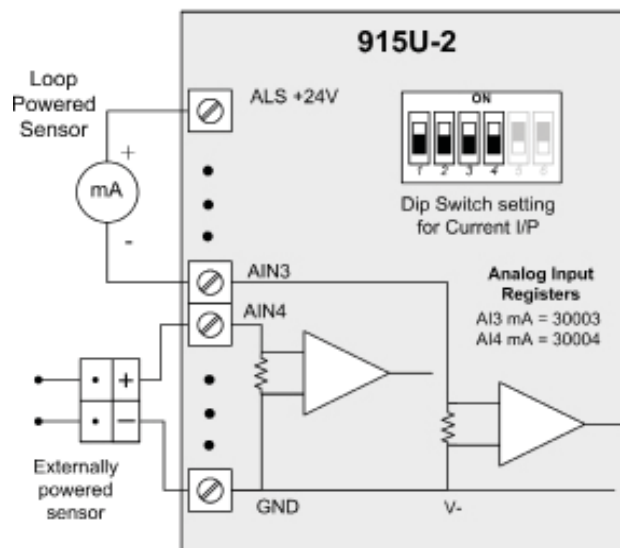

Figure 19 AI 3 & 4 Single-ended Current Inputs

Voltage Inputs

All analog inputs can be set up to read voltage. If using analog input 1 and 2, connect the voltage source across the positive terminal of the input and ground. If using analog input 3 and 4, connect across the input terminal and GND.

! NOTE Default scaling gives 0–20V for 4–20 mA output on analog 1 and 2. Default scaling for analog 3 and 4 gives 0–5V for 4–20 mA output. For voltage input on analog 3 and 4, set both DIP switches to the “off” position.

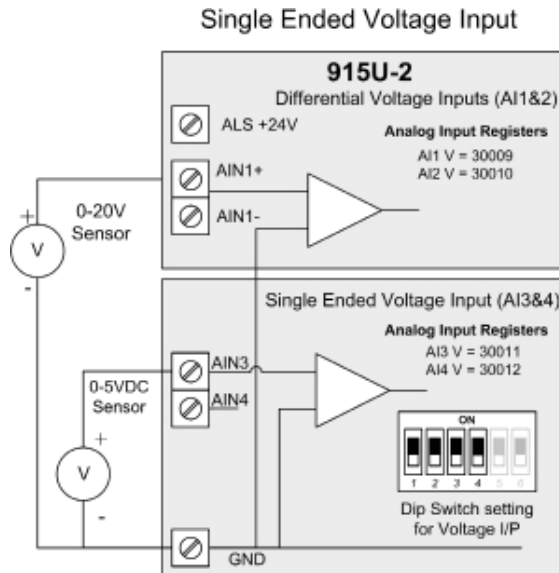

Figure 20 Voltage Inputs

Analog Outputs

The 915U-2 module provides two 0–24 mA DC analog outputs for connecting to analog inputs on equipment (such as PLCs, DCS, and loggers) or connecting to instrument indicators for displaying remote analog measurements. The 915U-2 analog outputs are a sourcing output and should be connected from the analog output terminal through the device or indicator to ground (GND). See Figure 21 for connections. The LEDs provide level indication depending on current. The LEDs appear dimmed for 4 mA and bright for 20 mA.

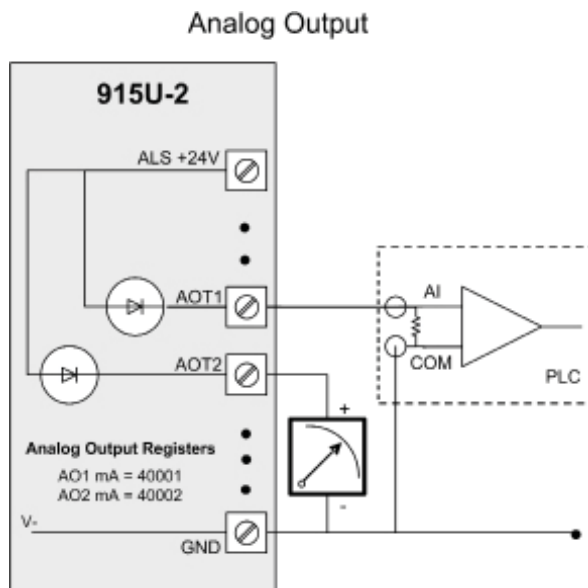

Figure 21 Analog Outputs

CHAPTER 3 - OPERATION

3.1 Overview

The 915U-2 Series I/O modules are designed to provide standard off-the-shelf telemetry functions at an economic price. Telemetry is the transmission of data or signals over a long distance via radio or twisted-pair wire cable.

3.2 LED Indicators

When the module is initially connected to power, it performs internal setup and diagnostics checks to determine if it is operating correctly. These checks take approximately 80 seconds. The following table shows how the LED indicators appear when the module is operating correctly.

Front Panel Indicators

LED Indicator	Condition	Meaning
PWR	Green	System OK
PWR	Red	System boot (initial or system failure)
PWR	Orange	Start of system boot
PWR	Fast Flash	System boot, stage 1
PWR	Slow Flash	System boot, stage 2
RF	Orange	Transmitting radio data
RF	Red	Receiving radio data
232	Green	Transmitting RS-232 data
232	Red	Receiving RS-232 data
232	Orange	Transmitting and receiving RS-232 data
485	Green	Transmitting RS-485 data
485	Red	Receiving RS-485 data

The RF LED does not directly represent the actual radio transmission status. It only indicates the first transmission from a mapping, an update, or an underlying AODV message. Any subsequent retry messages will not be indicated.

LED Boot Sequence

Upon reset, the PWR LED appears solid red for about 2 seconds (system boot), followed by 12 seconds of Orange (start of system boot process). The PWR LED then fast flashes between red and green for 30 seconds (stage 1 of system boot process) followed by a slow flashes for 50 seconds (stage 2 of system boot process). At the end of the boot sequence the PWR should appear solid green. The time periods are approximate, and depend on the hardware and firmware revisions.

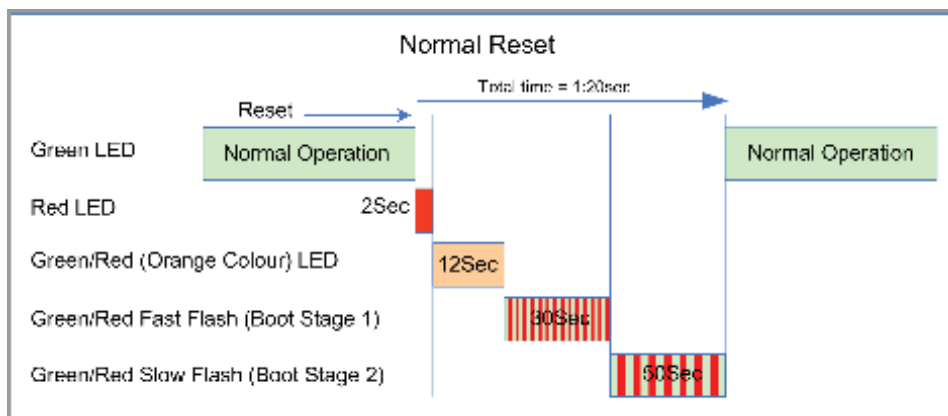
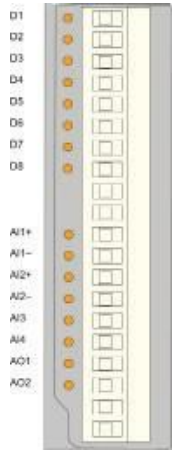

Figure 22 Boot Sequence

Input and Output Indicators

	LED Indicator	Condition	Meaning
	D 1–8	Orange	Digital input is on
	D 1–8	Flashing Orange - (Long On)	Update failure (fail-safe state is on)
	D 1–8	Flashing Orange - (Long Off)	Update failure (fail-safe state is off)
	AI 1 & 2 +	Orange	Analog input current indication
	AI 1 & 2 –	Orange	Analog input voltage indication
	AI 3 & 4	Orange	Analog input current or voltage indication
	AO1 & 2	Orange	Analog output current indication

Digital Inputs

LEDs display the status of each of the eight DIOs when used as inputs. If the LED is on, it indicates that the input is on.

Digital Outputs

When the DIOs are used as outputs, the LEDs display the status of each of the digital outputs. If an LED is on, it indicates that the output is on. The LEDs also indicate if the output is in a fail-safe state by flashing at different rates. If an LED is mostly on (long on) it indicates that the fail-safe state shown on the Digital Output Configuration page (in MConfig Utility) is on. If an LED is mostly off (long off) it indicates that the fail-safe state shown on the Digital Output Configuration page (in MConfig Utility) is off. See “Fail-safe Blocks” on page 53 for details.

Analog Inputs

There are two LEDs for each differential analog input. The first LED (+) is used to indicate that the analog input is reading a current (mA). The second LED (–) indicates that the input is reading voltage. Each of the analog input LEDs flash with increasing speed and intensity depending on the level of the input. For example, at 4 mA, the LED appears dimmed and flashes slowly, and at 20 mA the LED appears bright and flashes quickly.

For each of the single-ended analog channels, the LED indicates when the input is reading current or voltage by flashing the LED according to the level of the input. For example, at 4 mA the LED appears dimmed and flashes slowly, and at 20 mA, the LED appears bright and flashes quickly.

Analog Outputs

Each analog output has an LED in series that indicates the output current by increasing or decreasing the intensity of the LED. For example, at 4 mA the LED appears dimmed, and at 20 mA, the LED appears bright.

Ethernet LED Indicators

On the end plate, the Ethernet socket incorporates two LEDs that indicate the Ethernet status.

- 100M—Green LED indicates presence of a 100-Mbps Ethernet connection. With a 10-Mbps connection, the LED is off.
- LINK—Orange indicates an Ethernet connection. The LED briefly flashes with activity.

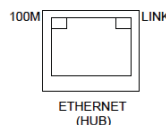

Figure 23 Ethernet Socket

3.3 System Design

Radio Channel Capacity

Messages sent on a cable link are much faster than on a radio channel, and the capacity of the radio channel must be considered when designing a system. This becomes more important as the I/O size of a system increases.

The modules are designed to provide “real-time” operation or change of state (COS). When an input signal changes, the change message is sent to the output. The system does not require continuous messages as in a polling system. Update messages are intended to check the integrity of the system, not to provide fast operation. Update times should be selected based on this principle. The default update time in the mappings is 10 minutes. It is recommended that you leave these times as-is unless particular inputs are very important and deserve a smaller update time.

It is important that the radio paths are reliable. For large systems, we recommend a maximum radio channel density of 300 messages per minute, including change messages and update messages. We suggest that you do not design the system with more than 300 messages per minute because this does not take into account network communication overheads. Note that this rate assumes that all radio paths are reliable and that the network topology (mesh) is stable. Poor radio paths will require retransmissions and will reduce the channel density. If there are other users on the radio channel, this peak figure will also decrease. Having remotes radios dropping in and out of communications can also increase overall network traffic because the network needs to relearn the communication paths each time the module comes back on line.

Dual Band Operation

The 915U-2 radio band is split into two sub-bands, 902–914 MHz (low) and 915–928 MHz (high). The radio sub-band can be changed by selecting the hopset band on the Radio webpage of the Web-based configuration utility (see “Radio Settings” on page 69).

In countries that utilize the full 902–928 MHz bandwidth (such as the United States and Canada) the 915U-2 uses both sub-bands, which makes it possible to force the frequency hopping to the other band (high or low) to avoid radio interference and to separate systems. In other countries, such as Australia and New Zealand, this option is unavailable because of the single band.

Radio Path Reliability

Radio paths over short distances can operate reliably with a large amount of path obstruction. As the path distance increases, the amount of obstruction that can be tolerated decreases. At the maximum reliable distance, line-of-sight is required for reliable operation. The curvature of the earth becomes more of an obstacle if the path is greater than several kilometers (or miles), and allowance needs to be made for this. For example, the earth’s curvature over five miles (8 km) is approx 10 feet (3m), requiring antennas to be elevated at least 13 feet (4m) to achieve line-of-sight even if the path is flat.

A radio path may act reliably in good weather, but poorly in bad weather. This is called a marginal radio path. If the radio path is more than 20% of the maximum reliable distance, we recommend that you test the radio path before installation (see Chapter 6 for maximum distances). Each 915U-2 module has a radio path testing feature. See “5.2 Mesh Connectivity” for more information.

There are several ways to improve a marginal path:

- Relocate the antenna to a better position. If there is an obvious obstruction causing the problem, locating the antenna to the side or higher will improve the path. If the radio path spans a long distance, increasing the height of the antenna will improve the path.
- Use an antenna with a higher gain. Before doing this, make sure that the radiated power from the new antenna remains within the regulations of your country. If you have a long coaxial cable, you can use a higher gain antenna to cancel the losses in the coaxial cable.
- If it is not practical to improve a marginal path, you can use another module as a repeater. A repeater does not need to be located between the two modules, although often it is. If possible, use an existing module in the system that has a good radio path to both modules. The repeater module can be to the side of the two

modules, or even behind one of the modules if the repeater module is installed at a high location (for example, a tower, or mast). Repeater modules can have their own I/O and act as a normal 915U-2 module within the system.

Design for Failures

All well designed systems consider system failure. I/O systems operating on a wire link will fail eventually, and the same is true for a radio system. Failures can be short-term, such as interference on the radio channel or power supply failure, or long-term, such as equipment failure.

The modules provide the following features for system failure:

- Outputs can reset if they do not receive a message within a configured time. If an output should receive an update or change message every 10 minutes and it has not received a message within this time, some form of failure is likely. If the output is controlling machinery, it is good design to switch off the equipment until communications are re-established.
- The modules provide a fail-safe feature for outputs. This is a configurable time value for each output. If a message has not been received for this output within the configured time, the output will assume a configured value. We suggest that this reset time be a little more than twice the update time of the input. It is possible to miss one update message because of short-term radio interference. However, if two successive update messages are missed, long term failure is likely and the output should be reset. For example, if the input update time is three minutes, set the output reset time to seven minutes.
- A module can provide an output that activates on communication failure to another module. This can be used to provide an external alarm indicating that there is a system fault.

Indicating a Communications Problem

Communications problems can be indicated using fail-to-transmit alarms or fail-to-receive alarms. These alarms can be configured using the Mapping screen within the MConfig Utility (see “Mappings” on page 42).

- **Fail-to-transmit Alarm**—The first method is to setup a communications indication on a register of your choice when configuring a mapping. This can be done using an existing mapping (no need to setup a special communications mapping). When entering a block write or gather/scatter mapping, enter a register location for a communications failure in the Fail Register field. This register can be a local DIO (Reg 1–8) or an internal register. Whenever the module tries to send this mapping and fails to get a response (ACK) it will turn on the physical output if using a DIO (reg1-8) to display the alarm, or if using an internal register the value will switch from “0” to “1.”

The communications failure indication will clear on the next successful transmission of the mapping. This method will work with any number of repeaters in the link. However, it will only indicate a failure to transmit if the Acknowledge checkbox is selected in the mapping. It will not provide a fail indication if the mappings are configured as transmit only (Acknowledge checkbox is not selected).

- **Fail-to-receive Alarm**—The second method is to set up a communications link indication on the receiving end using normal write mappings on the transmitting end and the fail-safe time function on the receiving end. Setup a communications mapping from an unused digital input (can be an internal signal, such as supply fail) and map it to the output that will indicate the communication status. The input will be updated on a time interval (default is 10 minutes). Reconfigure a time that will provide a good indication of failure (such as 30 seconds), but not update so often that it generates too many communication check messages.

On the receiving end, configure a fail-safe block on the output configured in the above mapping. Configure a “Fail Time Out” for a little over twice the mapping update time (for example, one minute, and 10 seconds). Next, configure a Fail Value of “1” to turn on the output when it fails to be updated. Alternatively, you could invert the mapping so the output is always on, and configure a Fail Value of “0” to turn off the output when not updated.

This method will work with any number of repeaters in the link. You should use separate outputs to indicate “Comms OK” of different remote modules.

WIBNet Communication Registers

The WIBNet radio has a number of registers available to indicate a communication failure with a particular remote address. General purpose digital registers 10501–10595 indicate a communication fail for the corresponding remote radio address. For example, address 10505 indicates a communication fail for remote address #5, and address 10590 indicates a communications failure for remote address #90.



NOTE The radio must have a valid mapping for the remote address and the mapping must have the acknowledgment (ACK) enabled.

Testing and Commissioning

We recommend that the system is fully bench tested before installation. It is much easier to find configuration problems on the bench when the modules are next to each other as opposed to being miles apart. When the system is configured and you are confident that it works, back up the configurations of all modules.

After installation, record the radio signal strength and background noise level for each radio link. See “5.4 Mesh Neighbor RSSI” on page 84 for details. If there are future communications problems, you can compare the present measurements to the as-commissioned values. This is an effective way to find problems with antennas and cables, and changes in the radio path that may be caused, for example, by new buildings being erected in the path.

3.4 WIBMesh

The ELPRO WIBMesh protocol is based on the Ad hoc On-demand Distance Vector (AODV) routing algorithm, a routing protocol designed for ad hoc networks. AODV is capable of unicast (single-addressed message) routing, and is an on-demand protocol, meaning that it builds and maintains these routes only as long as they are needed by the source devices. In other words, the network is silent until a connection is needed. The protocol creates a table that shows the connection routes to other device in the system and uses sequence numbers to ensure that the routes are kept as current as possible.

When a module in a network needs to make a connection to another module, it broadcasts a request for a connection. Other modules forward this message, and record the address of the module that they heard it from, creating a table of temporary routes back to the initiating module. If a module receives a request and it already has an existing route to the requested destination, it sends a message back through the temporary route to the requesting module.

Each request for a route has a sequence number. Modules use this sequence number in order not to repeat route requests that they have already passed on. Route requests also have a time-to-live number that limits how many times they can be retransmitted. If a route request fails, another route request may not be sent until twice as much time has passed as the timeout of the previous route request.

The module that initiated the request then begins using the route that has the least number of hops. Unused entries in the routing tables are recycled after a time. When a link fails, a routing error is passed back to a transmitting module, and the process repeats.

CHAPTER 4 - CONFIGURATION

The 915U-2 modules can be configured using the Windows-based Mesh and I/O Gateway Configuration Utility (MConfig), or via the embedded Web-based management utility. We recommend using MConfig as your primary configuration utility because it is easier to use than the Web-based configuration utility and simplifies the configuration process. The Web-based utility is required only when you need to modify wireless connection settings for all 915U-2 modules in the system. For more information, see "4.3 Web-Based Configuration Utility" on page 65.

4.1 Connecting to the Module

Use the following procedure to directly connect a PC to the 915U-2 in order to configure modules using the MConfig Utility or the Web-based configuration utility. Before connecting, make sure that the MConfig Utility is installed on the PC. For instructions, see "Downloading and Installing MConfig."

You will need a straight-through Ethernet cable for connecting to the module's Ethernet port. The module's default IP address, subnet mask, gateway IP address, and radio IP address are as follows:

- IP Address: 192.168.0.1XX, where "XX" is the last two digits of the serial number shown on the printed label on the side of the module
- Subnet Mask: 255.255.255.0
- Default Gateway: 192.168.0.1
- Radio IP Address: 192.168.2.1

1. Connect a straight-through Ethernet cable between the module's Ethernet port and the PC.
2. Restore the module's default settings if they are not the current settings:
 - a. Open the side configuration panel on the module, and set DIP switch #6 to "on."

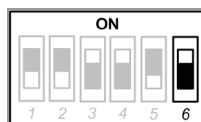

Figure 24 DIP Switch #6 in On Position

- b. Power cycle the module.

When the 915U-2 is powered on with DIP switch #6 set to "on," the module goes into Setup mode and temporarily loads its factory-default settings. In Setup mode, wireless operation is disabled. The previous configuration remains stored in non-volatile memory and will only change if a configuration parameter is modified and the change is saved.



IMPORTANT Remember to set DIP switch #6 to the "off" position and power cycle the module to return to normal operation after you have completed configuration. Otherwise, the module will continue to boot into the default IP address.

3. On the PC, open the Control Panel, and then click Network Settings.

The following description is for Windows XP. Earlier Windows operating systems have similar settings.

4. Open Properties of Local Area Connection.
5. Select Internet Protocol (TCP/IP) and click Properties.



Figure 25 Local Area Connection Properties

6. On the General tab, enter IP address 192.168.0.1 and subnet mask 255.255.255.0, and then click OK.

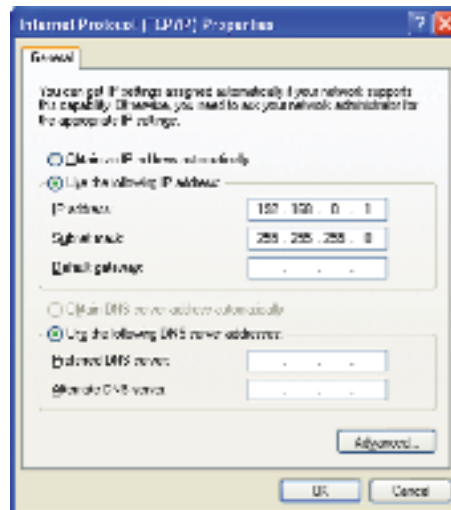
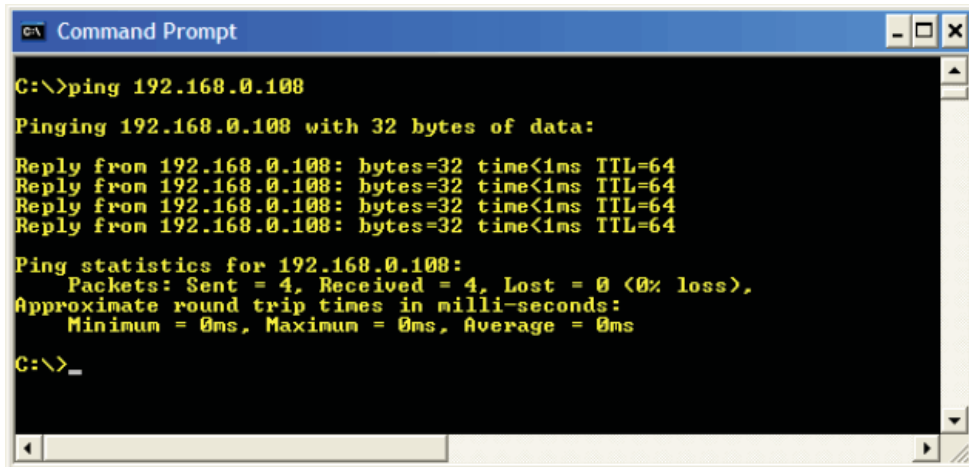

Figure 26 TCP/IP Properties

7. Verify the Ethernet connection to the module by using the “ping” command:
 - c. From the Windows Start menu, choose Run, and then type: command
A command prompt DOS window appears.
 - d. Type “ping 192.168.0.1XX”, where “XX” is the last two digits of the serial number shown on the printed label on the side of the module.
The ping response should look similar to Figure 27.



```

C:\>ping 192.168.0.108

Pinging 192.168.0.108 with 32 bytes of data:

Reply from 192.168.0.108: bytes=32 time<1ms TTL=64
Reply from 192.168.0.108: bytes=32 time<1ms TTL=64
Reply from 192.168.0.108: bytes=32 time<1ms TTL=64
Reply from 192.168.0.108: bytes=32 time<1ms TTL=64

Ping statistics for 192.168.0.108:
    Packets: Sent = 4, Received = 4, Lost = 0 (0% loss),
    Approximate round trip times in milli-seconds:
        Minimum = 0ms, Maximum = 0ms, Average = 0ms

C:\>_

```

Figure 27 Ping

- After verifying the connection, you are ready to configure modules using MConfig or the Web-based configuration utility. For information on MConfig, see “4.2 MConfig Utility.” For information on the Web-based utility, see “4.3 Web-Based Configuration Utility.”

4.2 MConfig Utility

The MConfig configuration utility is a Windows-based software program that allows system-wide configuration and diagnostics for WIBMesh and WIBNet-based products. The utility can be downloaded from the ELPRO website, and is compatible with all current Windows versions. MConfig uses a simple point-and-click interface that allows you to create projects, adjust parameters to suit the application specifics, program, and diagnose—all from a single point. You can also configure advanced settings, including:

- Over-the-radio link configuration and diagnostics
- Gateway functionality for Modbus TCP and RTU protocols
- Radio communications monitoring
- I/O point naming

Downloading and Installing MConfig

The MConfig Utility is provided as a zip file from the download section of the ELPRO website. Configuration of the 915U-2 module can be performed via USB or Ethernet connection, and all appropriate USB drivers are installed during installation. If you have a problem installing the drivers, you can install them manually using Windows Device Manager.

- Go to the ELPRO website: <http://www.elprotech.com> resources.
- Under Resources, click Technical Resources Library, and then click ELPRO Configuration Software.
- Download the zip file “915U-2 Wireless Mesh I/O and Gateway Configuration” to your PC and extract the zip file.
- Open the file “INST_CFG_MCconfig<version>.exe.”
This runs the Installation Wizard.
- Follow the on-screen instructions to install the software (see Figure 28).

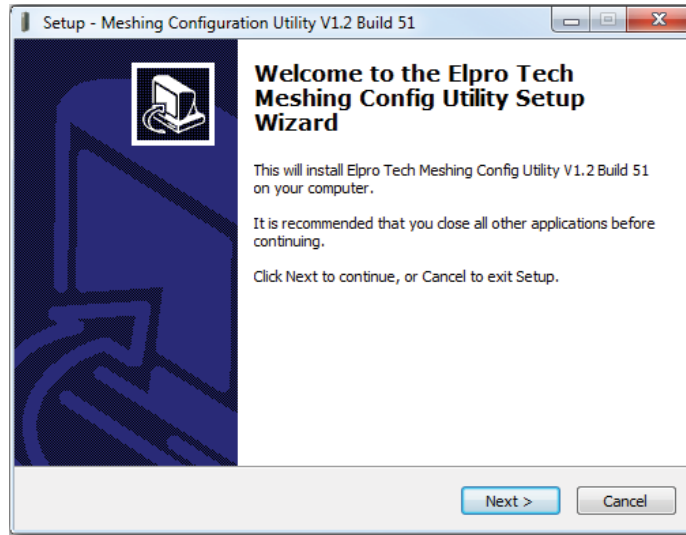

Figure 28 Installation Wizard

Starting MConfig

Follow these steps to start the MConfig Utility.

1. From the Windows Start menu, choose Programs-->Meshing Config Utility-->Meshing Config Utility.
The Project Selection screen appears.

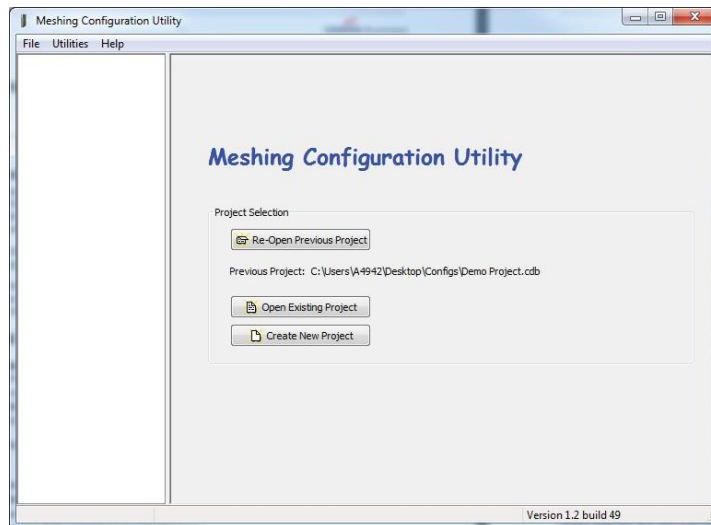

Figure 29 Project Selection

2. Click one of the following options:
 - Re-open Previous Project—Opens the last configuration project that was used on the PC. All configuration project files are typically stored locally on the PC or on a network drive. The path to the last project used appears below this button.
 - Open Existing Project—Opens any previously saved project. This can be a project that was created on the current computer or a configuration that was created elsewhere and sent to you. A dialog box will allow you to navigate to the saved project that you wish to open.
 - Create New Project—Start a new configuration project. You name the project and also specify the directory location where the project is to be saved. The directory can be on the PC, on a portable drive, or on the network.

The project screen appears (see Figure 30).

Project Screen

The Project screen is displayed when you open or create a project. The project tree on the left shows the project name, followed by any 915U-2 module units that have been added to the project (the project tree is empty when you start a new project). Clicking a module in the project tree opens a list of the module's configurable options. Clicking a configurable option displays the current configuration data on the right side of the screen. This is where you can make changes to current settings.

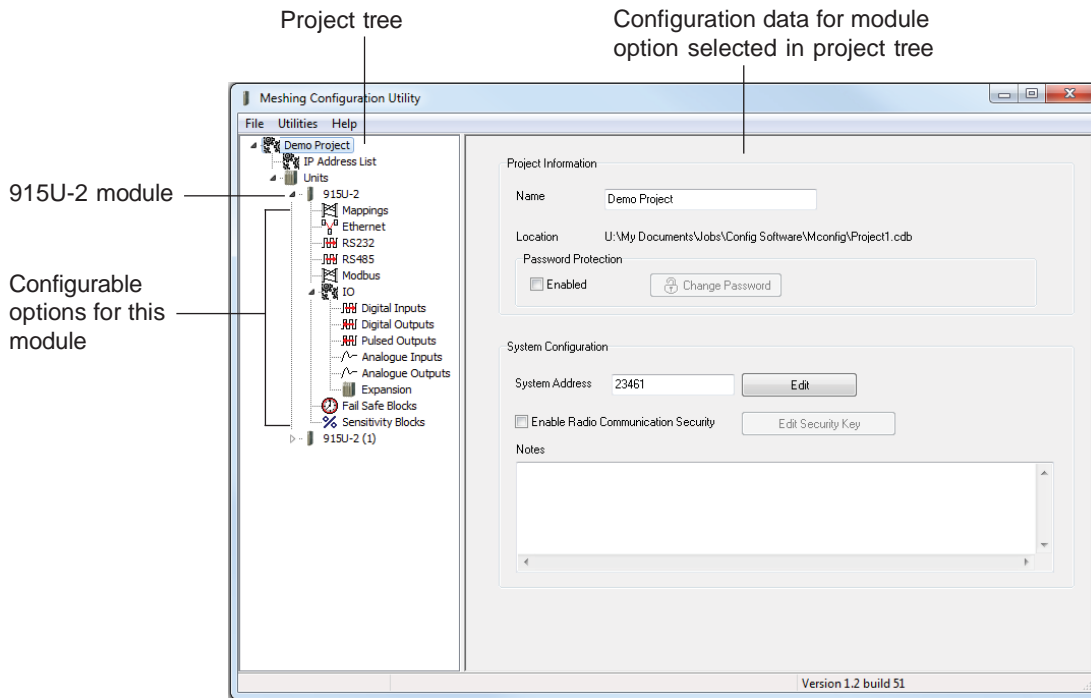

Figure 30 Project Information

The project screen contains the following fields.

- Project Information Includes the project name and the directory location of the project. You can change the project name by editing the field.
- Password Protection Allows you to enable or disable the security option. When enabled, a password is required to access to the configuration file. The password must be a minimum of six characters. Password protection does not provide security for the radio link. This is handled through radio communication security, which is configurable via the Web-based configuration utility. For more information, see “Radio Settings” on page 69.
- Change Password Allows you to change the current password.
- System Address Main network address that all radios will use. Each radio in a project has a unique address, but all radios in the same project must share the same system address. This allows you to have multiple individual systems operating within the same radio range as other WIBMesh radios. The range of the system address is 0 to 65535. You can edit the current system address by clicking Edit.
- Enable Radio Communication Security Selecting this checkbox causes an encryption key to be created for the radio network. You can edit the encryption key by clicking Edit Security Key. You can enter up to 32 characters for the key. After confirming the new key, click Apply. All radios will then need to be re-configured for successful communications to occur.

Adding Units to a Project

Click Units in the project tree to add a new 915U-2 configuration to the project or import (load) an existing 915U-2 configuration to the project. The new or imported 915U-2 will appear in the project tree. A configuration can be imported by directly connecting to a 915U-2 module over Ethernet or USB, or by selecting a pre-saved configuration file from a 915U-2 module.



NOTE If you plan to use over-the-air configuration to update modules, after adding the module units to the project refer to Appendix G for instructions on configuring them for over-the-air configuration.

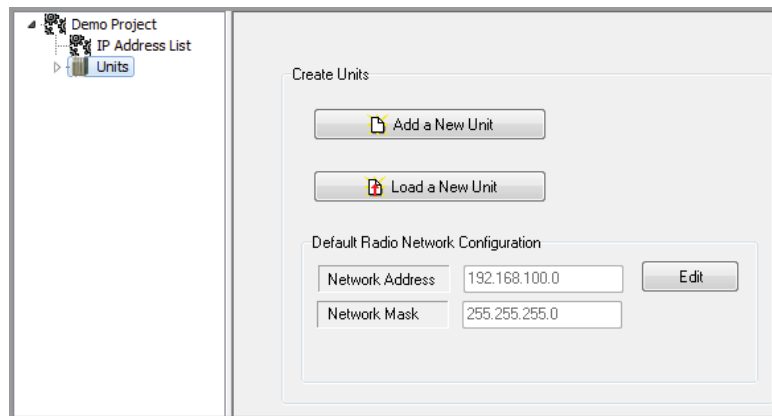

Figure 31 Create Units

Default Radio Network Configuration

This field allows you to change the default radio IP address and network mask. The WIBMesh protocol is an IP-based protocol, which means that the radio network will have an IP address range assigned to it. The default network base address is 192.168.100.0. Each radio will have a radio IP address assigned to it, starting at 192.168.100.1 and incrementing as each radio is added to the configuration. This IP address range does not usually need to be changed because only WIBMesh protocol radios can communicate to each other.

Even though the WIBMesh protocol is based on an IP standards-based protocol, it is still not an open standard, such as Wi-Fi. This means that you cannot connect directly to the 915U-2 using your PC. Each 915U-2 radio acts like a router, which also means that this radio IP address will not conflict with network adapters. If there is a requirement for the radio IP address to be changed, you can change the address by clicking the Edit button next to the IP address .

Once a 915U-2 module is added to the project, selecting the module in the project tree displays the Unit Details screen where you can enter or change information about the module.

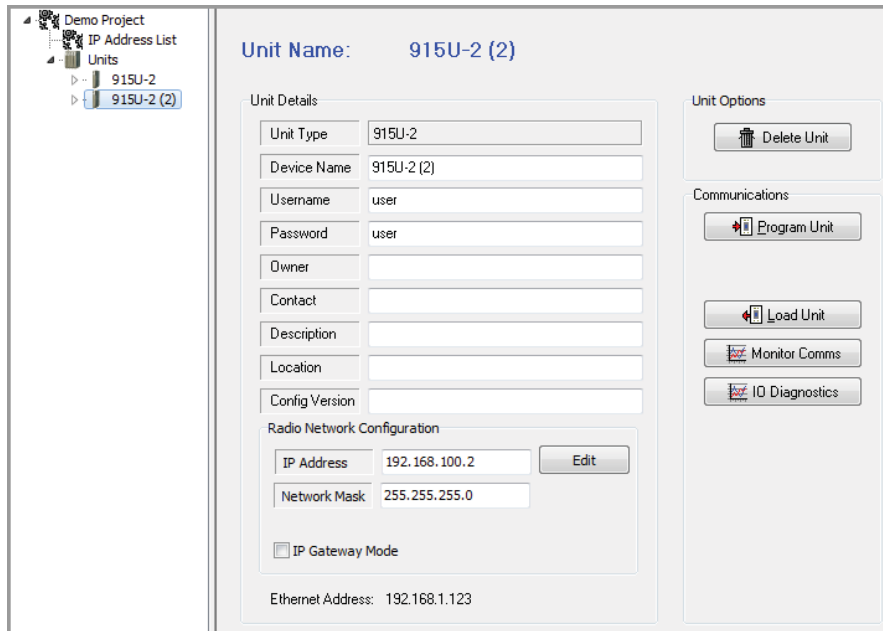

Figure 32 Unit Details

Unit Type	Radio model.
Device Name	Unique name that can be assigned to the software and radio.
Username and Password	Used to access the 915U-2 module in order to program, load, and diagnose issues. Prevents unauthorized access to the 915U-2 module.
Owner, Contact, Description, and Location	Details that you can add to provide information about the module.
Configuration Version	Displays the time and date when the current firmware was last updated. This information is not editable and is only updated when the module is programmed or read.
Radio Network Configuration	Radio IP address of module, as described in “Adding Units to a Project.”
IP Gateway Mode	Select this option when using the 915U-2 as the main gateway node to allow for remote over-the-air access for activities such as remote configuration or displaying diagnostics.
Ethernet Address	IP address of the actual physical Ethernet port on the 915U-2 module. Details for setting the IP address are found in “Editing Module IP Addresses” on page 41.
Delete Unit	Removes the 915U-2 from the project (no undo).

- Program Unit** Displays the Program Unit screen (see Figure 33) where you can choose the method to be used to configure the module:
- Ethernet (Local)— Program the module using the local Ethernet interface displayed in the list. Select IP Address or enter a new address.
 - USB Externally Powered—Program the module using a USB interface. You will need to plug in the USB cable and then click Refresh.
 - Configuration File (XML)—Program the module configuration to an XML file.
- Load Unit** Allows you to read the configuration data from the module radio and load it into MConfig, replacing the configuration currently in MConfig for this module (see Figure 34). Select the method that will be used to read the configuration data from the module:
- Ethernet (Local)—Load the configuration from the module using the local Ethernet interface displayed in the list. Select IP Address or enter a new address.
 - USB Externally Powered—Load the configuration from the module using the local Ethernet interface displayed in the list. Select IP Address or enter a new address.
 - Configuration File (XML)—Load a configuration XML file into the currently selected module in the MConfig utility.
- Monitor Comms** Displays a diagnostic tool that allows you to look at radio communications between the unit and any equipment it is connected to via radio.
- IO Diagnostics** Allows you to view the internal registers for the selected module unit (see Figure 35).

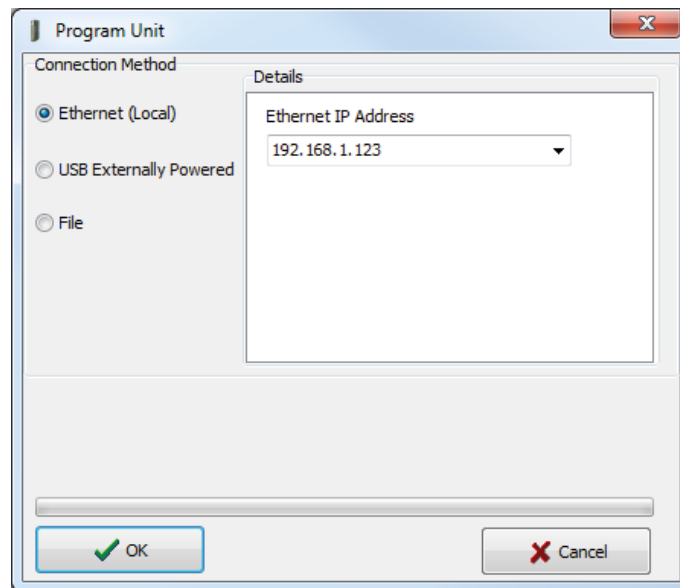

Figure 33 Program Unit

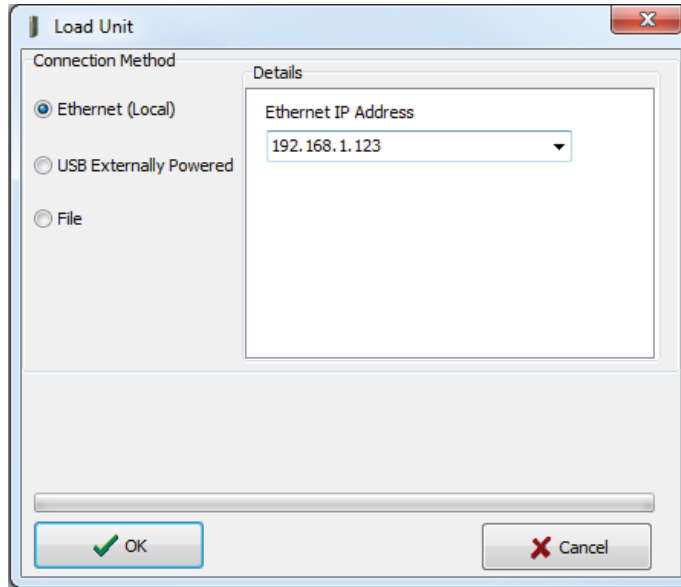

Figure 34 Load Unit

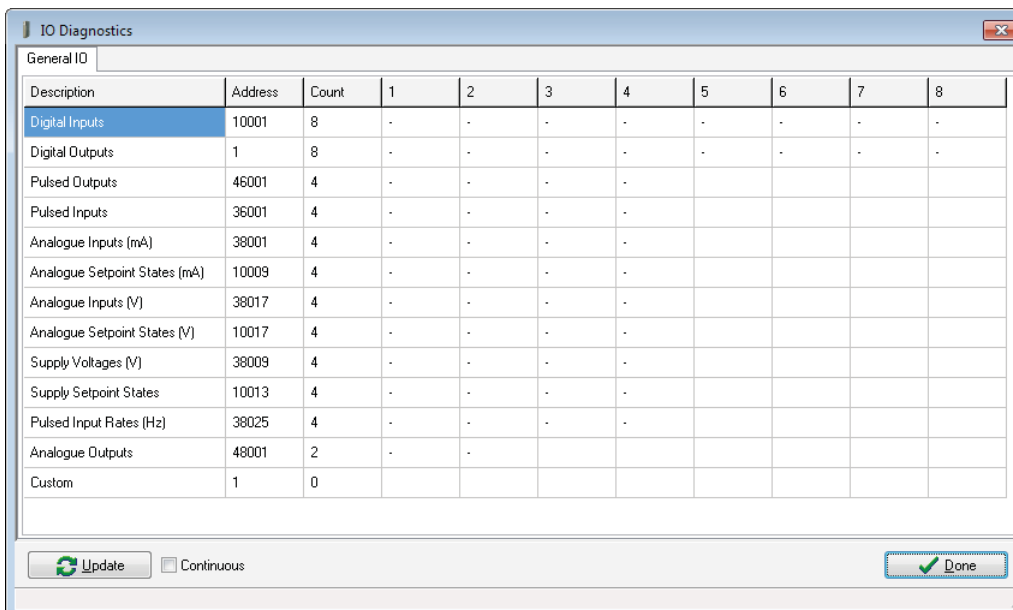

Figure 35 IO Diagnostics

Displaying the IP Address List

Click IP Address List in the project tree to display the module name and corresponding radio and Ethernet IP address, subnet mask, and network address for each module in the project. The IP address list is a read-only screen. To change a module IP address, see “Editing Module IP Addresses” on page 41.

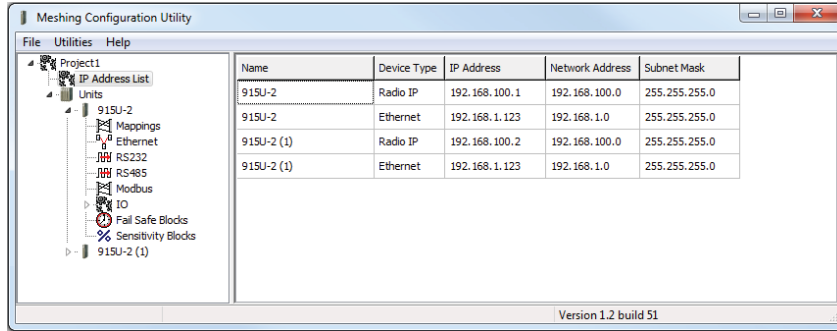

Figure 36 IP Address List

Editing Module IP Addresses

The radio IP and Ethernet IP addresses that display when you click IP Address List in the project tree are configured within other screens.

The radio IP address is normally set automatically, based on the Default Radio Network Configuration settings on the Units screen (see “Adding Units to a Project” on page 37). New modules are assigned a radio address based from this default. The radio IP address can also be manually edited by clicking the 915U-2 module in the project tree, and then clicking Edit (see Figure 32).

The Ethernet IP address can be edited by clicking Ethernet in the project tree, and then entering in an appropriate address and network mask. This page also allows the Ethernet interface to be disabled by deselecting the “Enabled” checkbox. In addition, selecting the “Obtain IP Address Automatically” checkbox will enable the module to communicate with a DHCP (Dynamic Host Configuration Protocol) server (if available), which will then assigns it an IP address. The default gateway address can also be edited here or disabled by selecting the “Use Default Gateway” checkbox.

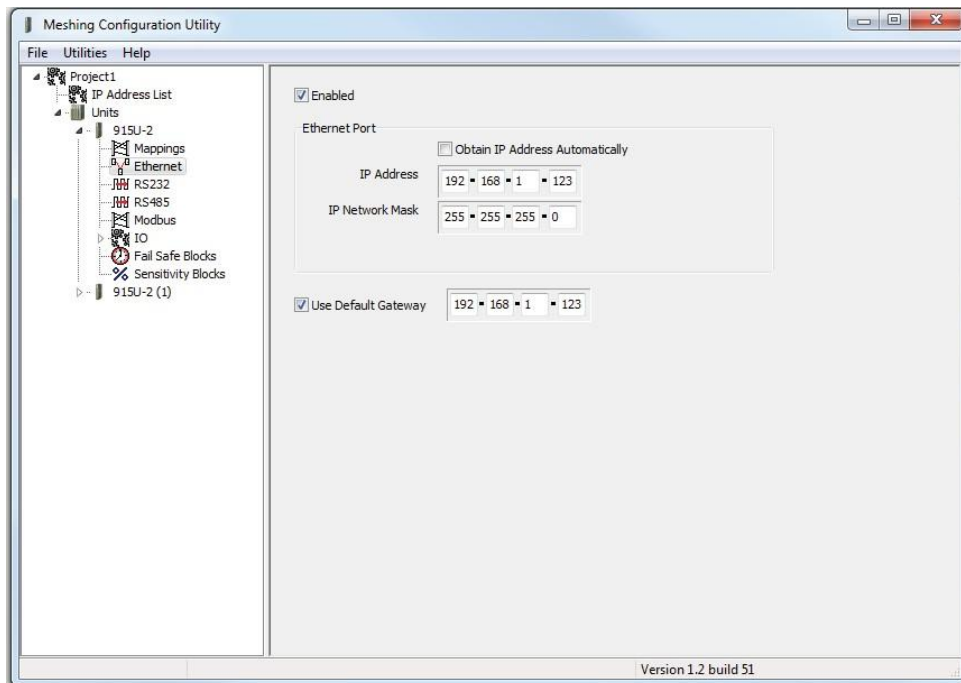

Figure 37 Ethernet

Mappings

Mappings are used to send I/O values between 915U-2 modules. The I/O value is typically sent via the radio interface, but at times it can be sent via the Ethernet interface between modules. To display the current mappings for a module, open the module in the project tree and click Mappings (see Figure 38).

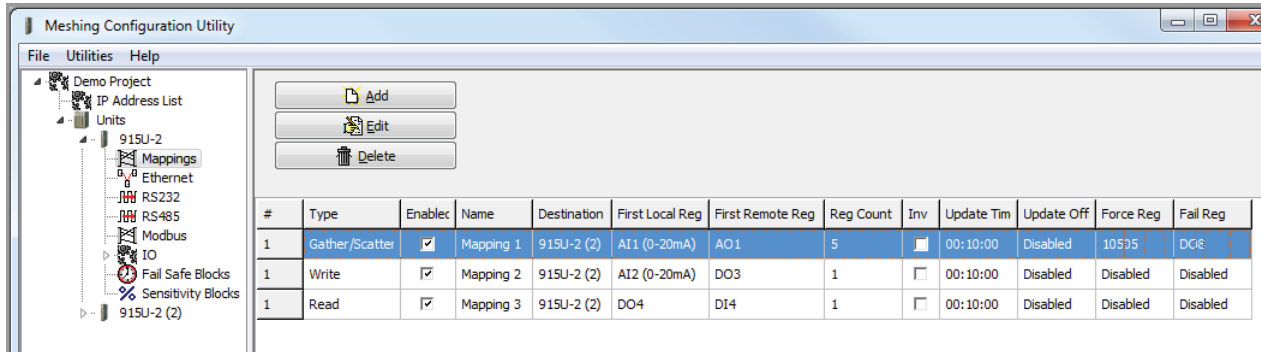

Figure 38 Mappings

Mappings are sent on the following triggers:

- **Change of state (COS)**—This method monitors the state of the input that is being mapped. When the state changes, it triggers a transmission. This is the primary method of sending input values to a destination. As soon as the input change occurs the value is immediately sent to the destination. Digital mappings are triggered when the input changes from on to off, or from off to on. Analog mappings are triggered when the input changes by a predefined value, referred to as “sensitivity.” The sensitivity value is set by configuring a sensitivity block for the particular input or a range of inputs. See “Sensitivity Blocks” on page 55 for more information.
- **Updates**—This method sends a message at a pre-configured time regardless of the input value or state. For details, see the Update Time field described in “Adding or Editing Mapping Parameters” on page 43.

There are three types of mappings—write, gather scatter, and read. Each type has advantages and disadvantages. The appropriate mapping to use will depend on the data and requirements of the system.

- **Write mapping**—A multi-I/O mapping allows multiple sequential values to be sent in one message. If you are mapping analog values, the maximum I/O count is 64. However, if you are mapping digitals it can be as many as 1024 because the digitals values are packed into 16-bit words for transmission. The mapping is sent on a change-of-state of any of the values being monitored, and also on an update period.
- **Gather scatter mapping**—A gather scatter mapping is essentially the same as write mapping, but instead of sequential register it allows different I/O types to be sent in a single message. All I/O types, including digital, analog, long (32-bit registers) and floating point values, can be sent in a single message. A gather scatter mapping has a maximum I/O count of 32 values of any data type (digital, analog, longs, or floats).
- **Read mappings**—Read mappings are similar to write mappings in that they allow multiple sequential values to be sent. However, instead of writing the values to another module it sends a message or polls the sending module and requests that the values be sent. This type of mapping is more like a polling system because the receiving station initiates when it wants to communicate, for example, by sending a read request when it requires the information or by sending a request on a timed basis.

Adding or Editing Mapping Parameters

To add a new mapping for a module or to edit existing mapping parameters, open the module in the project tree, click Mappings, and then click Add (or Edit). Figure 39 provides an example of a gather scatter mapping.

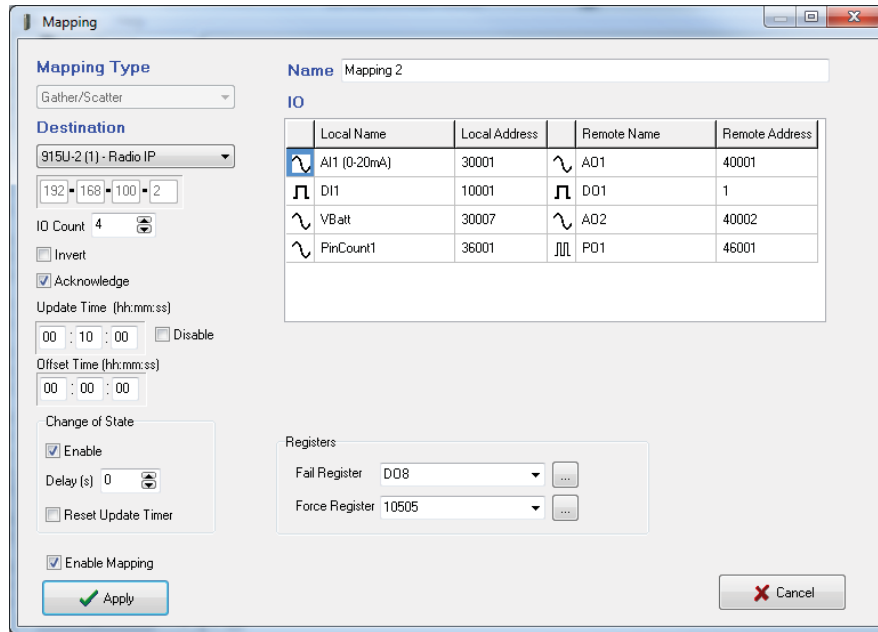





Figure 39 Gather Scatter Mapping

Name Each mapping can be given a name for reference purposes.

Destination Provides two standard choices, as well as a radio IP and an Ethernet IP address for each 915U-2 module in the project tree.

- **Local Host**—This option is the standard name given to the address of the loopback network interface and refers to the module that you are currently configuring. When this option is selected, the IP address changes to the localhost loopback address of 127.0.0.1.
- **IP Address**—This option allows any IP address to be entered in the configuration. It is for advanced users only because the remote name and address location will not show up in the I/O list. Knowledge of the remote module’s I/O location and address is required for it to function correctly. Generally this option is only used when a module that is not in the project is loaded or is being mapped to.
- **Radio IP Address**—When the radio IP address is selected, the mapping will be sent over the radio network. This is the most common destination selection.
- **Ethernet IP Address**—When Ethernet IP address is selected, the mapping will be sent to the Ethernet address port of the 915U-2. Click the Ethernet option in the project tree and ensure that the Ethernet port is enabled for the sending and receiving 915U-2 modules. Also ensure that the IP addresses of the sending 915U-2 and receiving 915U-2 are able to communicate to each other. For more information, see “Editing Module IP Addresses” on page 41.

IO Table	<p>Allows you to map each I/O to an output.</p> <ol style="list-style-type: none"> 1. Click the Local Name field to see a drop-down list of all available I/O, or click the Local Address field to view a tabbed I/O selection screen that will allow you to select an I/O point (input) that you want to map. 2. Select a destination I/O location. Click Remote Name for a drop-down list of destination I/O names or Remote Address to open a drop-down list of destination I/O locations. <p> NOTE A destination address must be selected before a remote name or remote address can be selected.</p>
I/O Count	<p>Allows you to add more I/O points to the mapping. If you are using a write and a read mapping, MConfig will automatically select consecutive registers that are shaded and cannot be edited. When using a gather scatter mapping, MConfig will add mapping entries which you must then edit by selecting the sending and destination I/O points.</p>
Invert	<p>Select this checkbox to allow the mapping to be inverted. For example, if the digital input is “on” and the mapping is inverted, the output will be “off,” or if an analog input is 4 mA and the mapping is inverted the output will be 20 mA. The invert applies to all I/O in the mapping. Floating point and long values are not inverted.</p>
Acknowledge	<p>Select this checkbox to allow a second level of message acknowledgments to be configured into the radio messaging. All normal WIBMesh protocol messages use message acknowledgment, but these are radio-to-radio communications, not source-to-destination. Selecting the Acknowledge checkbox allows the mapping to be acknowledged when the end device receives the message. This is an end-to-end acknowledgment, and is in addition to the normal hop-by-hop frame acknowledgment between links.</p> <p> NOTE Enabling this option will increase the amount of radio communications and care should be taken in larger systems.</p>
Update Time	<p>Configures how often the mapping update messages (check signals) are sent. These messages are in addition to the normal change-of-state updates that occur when an input changes.</p> <p>The default update time is 10 minutes, but it can be increased to a maximum of 18 days, 12 hours, and 15 seconds, or decreased to a minimum of one second. Updates can also be disabled by entering a time of zero or selecting the checkbox. Note that the updates are only a check signal, and care should be taken when configuring the update values with short update times (less than 5 seconds) because this will greatly increase the amount of radio traffic.</p>
Offset Time	<p>Configures an offset time for the update mapping. The offset is used to stagger the update transmissions at startup and at every update period so that the module does not send all mappings at the same time. The default is 0, but the typical offset time is around five seconds.</p>
Response Time	<p>(Read mappings only.) The countdown time before the module registers a communications failure for the configured read mapping. When the timeout is complete, the fail register is activated. This setting is normally used only with read mappings communicating through repeaters, because a direct mapping will use the update periods response as a timeout.</p>
Change of State Enable	<p>When selected, the values are sent to their configured destination when a change-of-state (COS) occurs and the value complies with any sensitivity blocks. If COS is disabled, messages will only be sent on the update period.</p>

Change of State Delay	Allows you to set the time period during which the message is delayed from being sent. The purpose is to reduce the amount of radio traffic by holding off the transmission to allow more I/O COS to the mapping.
Change of State Reset Update Timer	If this option is selected, the Update Time period will reset when a COS is received between configured updates. This means that the next update will not be sent until a further update period has elapsed. This option can be used to reduce the amount of radio traffic produced when multiple mappings are configured.
Fail Register	Allows you to configure a register location that will indicate a communication failure for the configured remote destination address.  NOTE The Acknowledge checkbox must be selected for fail registers to work. Also, the fail register can only be a digital output or internal bit registers (10501, 501, and so on).
Force Register	Allows you to configure an I/O location that will force the mapping to be sent when the I/O location is written to. External devices, such as Modbus Master/Clients, can initiate the transmission of a mapping by writing to an internal register that then forces the transmission to occur. For more information and examples, see “Startup or Force Configuration” on page 45.  NOTE Digital inputs 1–8 cannot be used as a force trigger because the digital inputs are continually being scanned by the internal processor and each time a scan occurs it would force the mapping to be sent. If a digital input is required to be used as the trigger, map the digital input to a general purpose bit storage register (501, 10501, and so on), and then use this general purpose register to trigger the force mapping.
Enable Mapping	Select the checkbox to enable this mapping.
Apply	Saves the current settings.

Startup or Force Configuration

When a module is first powered on, it transmits update messages to remote modules based on how the input mappings are configured. The module’s outputs will remain in the default “off” condition until the module receives an update or change-of-state message from the remote modules—unless a fail-safe block has been configured for the output, in which case it will default to the value configured in the fail-safe block. For more information, see “Fail-safe Blocks” on page 53.

To ensure that the module outputs are updated with the latest remote input status when the module is first powered on, you can configure the module to transmit a special startup or force message that will write a value into an internal register at the remote module (or modules). The remote module can then use this register to force any mappings that it has configured for the destination. To configure a force register, see the previous section, “Adding or Editing Mapping Parameters” on page 43.

When the force register is activated, any mapping configured with this force register will immediately send an update message to the destination so that its outputs can be set to the latest value. It may be necessary to configure a startup or force message for each remote module that sends values back to the module’s outputs.

Example

In the example shown in Figure 40, site A needs to be configured so that on power-up it writes to a register at Site B. Site B then uses this register to trigger an update of any mappings it has that communicate back to Site A. If the system has multiple remote sites that require startup or force configuration, Site A needs to have configured a startup or force mapping for each remote site. If there were multiple remotes in this example, all mappings from the remote sites that are sent to Site A would use the force register configured for 501.

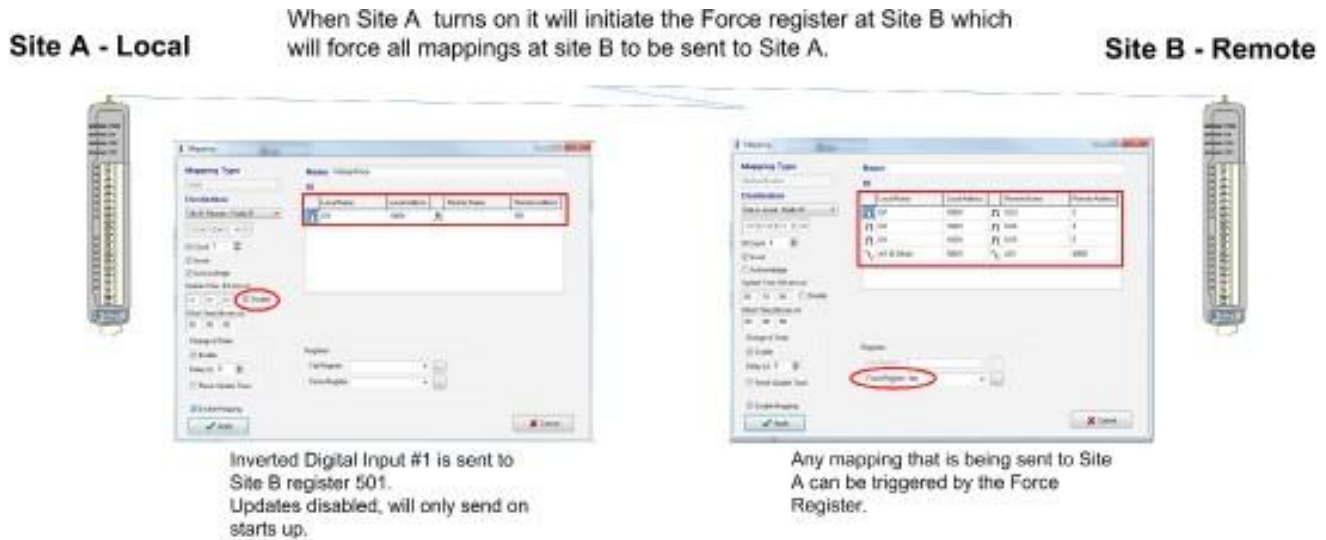

Figure 40 Startup or Force Configuration

Address Map

The I/O data store provides storage for all I/O data, both local data and data received from the system. The I/O store provides four register types—two bit registers, two word registers, two long-word registers, and two floating point registers. In addition, each register type supports both inputs and outputs, making a total of eight register addresses that are used for physical I/O and gateway storage. These files are mapped into the address range as described in the following table. The addressing uses standard Modbus protocol formatting and is also common to the ELPRO protocol.

Type	Size	Address
Discrete outputs	3000 (bits)	00001
Discrete inputs	2500 (bits)	10001
Word (unsigned) inputs (16-bit)	2500 (words)	30001
Word (unsigned) outputs(16-bit)	2500 (words)	40001
Long inputs (32-bit)	20 (longwords)	36001
Float inputs (32-bit)	20 (floats)	38001
Long outputs (32-bit)	20 (longwords)	46001
Float outputs (32-bit)	20 (floats)	48001

Common I/O Registers for the 915U-2

The following table shows the basic on-board I/O registers available in a standard 915U-2 module with no expansion I/O connected to it. For a detailed I/O map showing the full register range, see Appendix B.

Address	Input / Output Description
0001–0008	Local DIO1–DIO8, as outputs
10001–10008	Local DIO1–DIO8, as inputs
10009–10020	Set point status from analog inputs 1 through 12: <ul style="list-style-type: none"> • AI1, 2, 3, 4 current mode • Internal supplies • AI1, 2, 3, 4 voltage mode
30001–30004	Local AI1–AI4 (current mode): <ul style="list-style-type: none"> • AI1 and AI2, 4–20 mA diff • AI3 and AI4, 4–20 mA sink
30005	Local supply voltage (0–40V default scaling)
30006	Local 24V loop voltage (0–40V default scaling)
30007	Local battery voltage (0–40V default scaling)
30008	115S expansion I/O supply voltage (0–40V default scaling)
30009–30012	Local AI1–AI4 (voltage mode): <ul style="list-style-type: none"> • AI1 and AI2, 0–20V • AI3 and AI4, 0–5V
30013–30016	Local pulse input rates PI1–PI4
36001–36008	Local pulsed input counts (PI1 most significant word is 36001 and least significant word is 36002)
38001–38032	Local analog inputs as floating point values (mA, volts, or Hz)
40001–40002	Local AO1–AO2
48001–48002	Local AO1–AO2 as floating point values (mA)

I/O Configuration

Each I/O has different characteristics that can be tailored to applications. To configure I/O settings for a module, click I/O in the project tree to display the configurable parameters. These parameters are described in detail in this section.

Digital Inputs

To configure digital inputs, click Digital Inputs under IO in the project tree. Select a digital input from the list on the right, and click Edit (see Figure 41). This displays the IO Edit screen (Figure 42) where you can change settings.

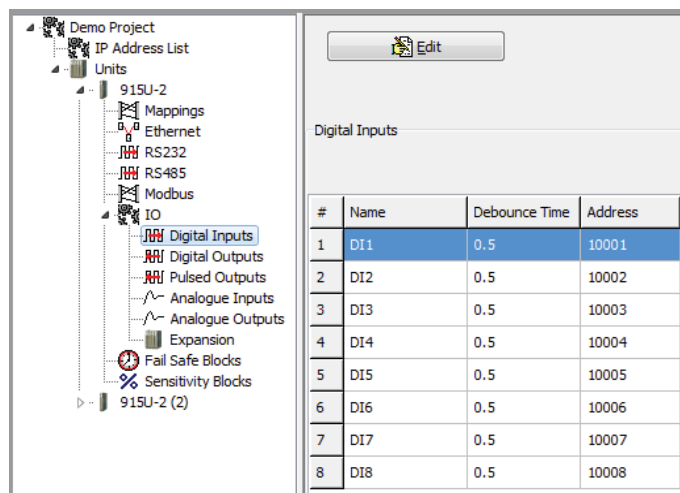

Figure 41 IO - Digital Inputs

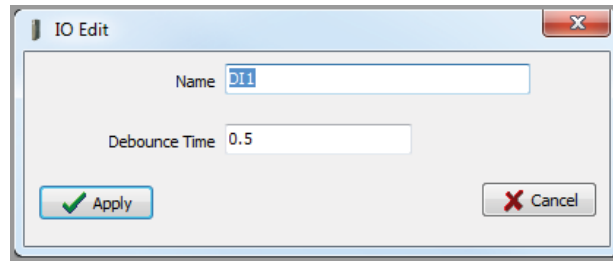

Figure 42 I/O Edit (Digital Inputs)

The following parameters can be configured for 915U-2 digital inputs.

- Name** Enter a name for the digital input or leave the default name. The name can be up to 30 characters, including spaces.
- Debounce Time (sec)** Debounce is the period of time that an input must remain stable before the module determines that a change of state has occurred. If a digital input changes from on to off and from off to on in less than the debounce time, the module will ignore both changes. The default debounce time is 0.5 seconds.

Digital Outputs

To configure digital outputs, click Digital Outputs under IO in the project tree. Select a digital output from the list on the right and click Edit. This displays the IO Edit screen (Figure 43) where you can change settings.



Figure 43 IO Edit (Digital Output)

The following parameters can be configured for 915U-2 digital outputs.

- Name** Enter a name for the digital output or leave the default name. The name can be up to 30 characters, including spaces.
- Fail-safe Time (sec)** Sets the time the output needs to count down before activating the fail-safe state. Receiving an update or a COS message will reset the fail-safe timer to its starting value. If the fail-safe timer goes down to zero, the output will be set to the fail-safe state (on or off).

It is recommend the fail-safe time be configured for a little more than twice the update time of the input that is mapped to it. That way, the output will reset if it fails to receive two update messages.
- Fail-safe State** Sets the state that the output will assume after the fail-safe time has elapsed. When the fail-safe state is enabled (on), the LED flashes briefly off, and the digital output turns on. When the fail-safe state is disabled (off), the LED flashing briefly on, and the digital output turns off.

Pulsed Outputs

To configure pulsed outputs, click Pulsed Outputs under IO in the project tree. Select a pulsed output from the list on the right, and click Edit. This displays the IO Edit screen (Figure 44) where you can change settings.

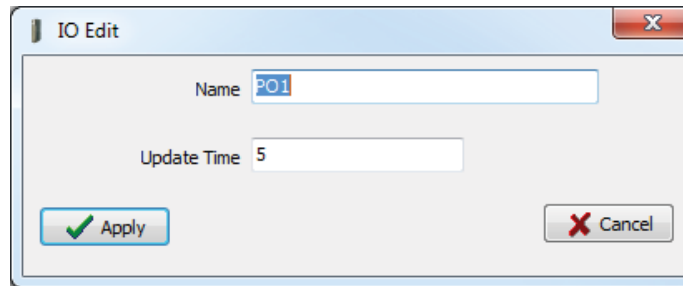

Figure 44 IO Edit (Pulsed Output)

The following parameters can be configured for 915U-2 pulsed inputs.

- Name Enter a name for the pulsed output or leave the default name. The name can be up to 30 characters, including spaces.
- Update Time (sec) Time that the output will be updated with the latest received value. The time is related to the update time of the pulsed input that is mapped to it. For example, if the pulsed input update time is configured for 10 seconds, the number of pulses will be counted and sent to the receiving module every 10 seconds. The receiving module will then output the pulse count over the configured update time (10 seconds).

Analog Inputs

Analog inputs have more configurable options because each input also has a set point assigned to it. Analog inputs can also be used as voltage inputs by selecting DIP switches on the 915U-2 modules (see “DIP Switches” on page 20).

To configure analog inputs, click Analog Inputs under IO in the project tree. Select a digital input from the list on the right, and click Edit (see Figure 45). This displays the IO Edit screen (Figure 46) where you can change settings.

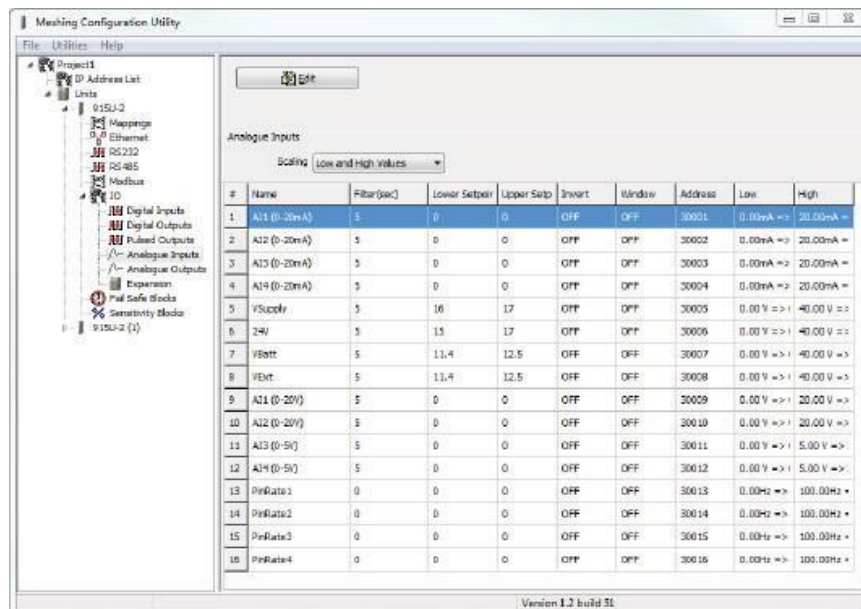

Figure 45 Analog Inputs

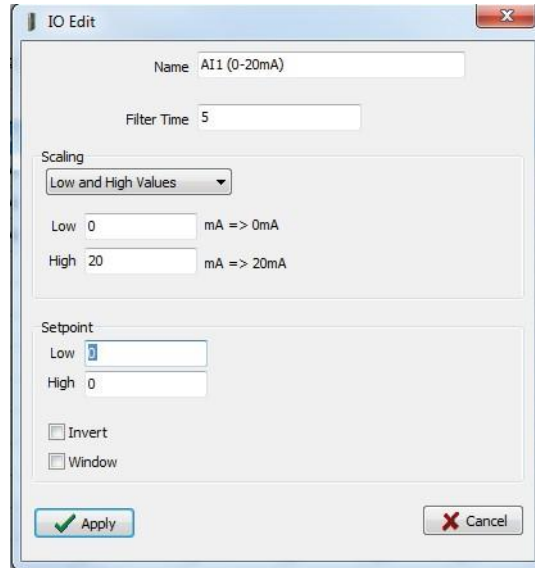



Figure 46 IO Edit (Analog Inputs)

The following parameters can be configured for 915U-2 analog inputs.

- Name Enter a name for the analog input or leave the default name. The name can be up to 30 characters, including spaces.
- Filter (sec) Period of time (in seconds) needed by the analog input to settle on a step change of an analog value. By default, all inputs except the pulse rates have a time constant of five seconds. Pulsed input rates are not filtered.
- Scaling Shows the input scaling in either Low-High values or Zero-Span values. These variables will change the scale of the analog inputs.
 - Low—The low engineering value for the input.
 - High—The high engineering value for the input (mA, V, Hz, and so on).
 - Zero—Starting value (counts) when the measured value is zero.
 - Span—Number of counts per measured value (mA, V, Hz, and so on).

The analog scale is linear, with an overall raw range of 8192 to 49152 decimal (total = 40960). The input engineering range can have many different forms, such as 0–20 mA, 0–5V, or 0–1000 Hz. This why the zero and span can be scaled to give the correct value.

- Lower and Upper Set Points These set points are the upper and lower control point values that will be used to turn on and off the analog set point digital signals located at register 10009–10020.

 **NOTE** Set point values are entered in the scale of the input. For example, analog input 1–4 should be in mA, analog inputs 9–12 should be volts, and so on.

The set points can be controlled by using the Invert and Window control options explained below. All set points have these controlling options.

- Invert Selecting this option inverts the set point control logic. The function does not change—only the operation is inverted. For example, if the set point is “on” in its normal state, inverting the signal causes the set point to be “off” in the normal state. By default, the checkbox is deselected and the set point logic is not inverted.

Window

Selecting this option sets the set point operation to Window mode. Deselecting this option sets the set point operation to default mode.

- Window Mode—In this mode, if the analog value is inside the upper and lower set points, the set point will be active (on, “1”), and if the analog value is outside of these set points the set point will be reset (off, “0”).
- Default Mode—In this mode, the set point operates in default mode. If the analog input is greater than the Upper Set point, the set point status will be active (on, or “1”). When the analog input is less than the Lower Set point the set point will reset (off, or “0”).



NOTE The upper set point must always be higher than the lower set point.

Analog Outputs

To configure analog outputs, click Analog Outputs under IO in the project tree. Select an analog output from the list on the right, and click Edit (see Figure 47). This displays the IO Edit screen (Figure 48) where you can change settings.

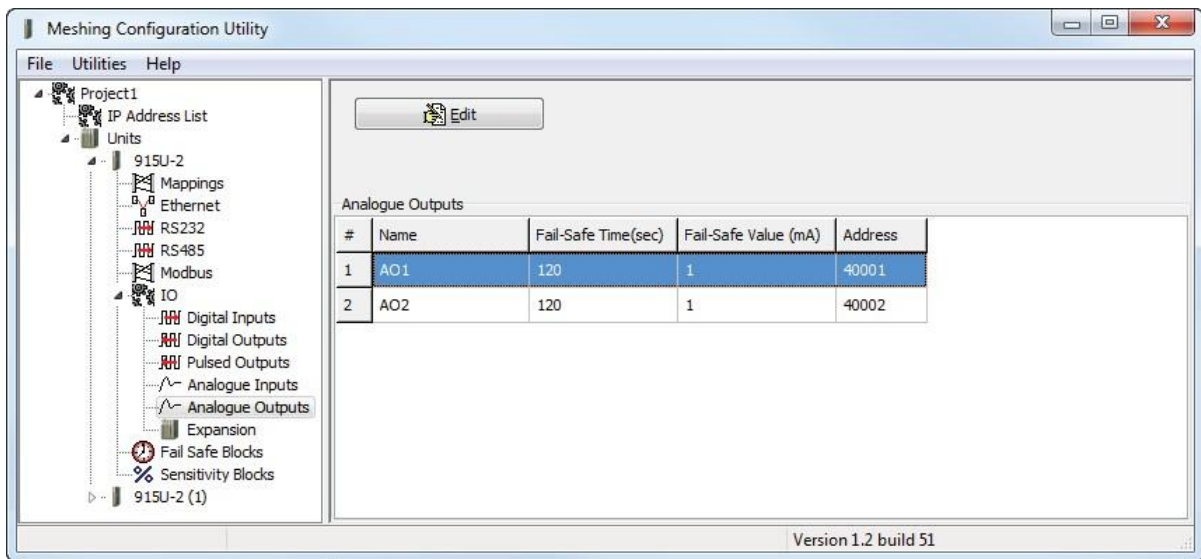

Figure 47 Analog Outputs

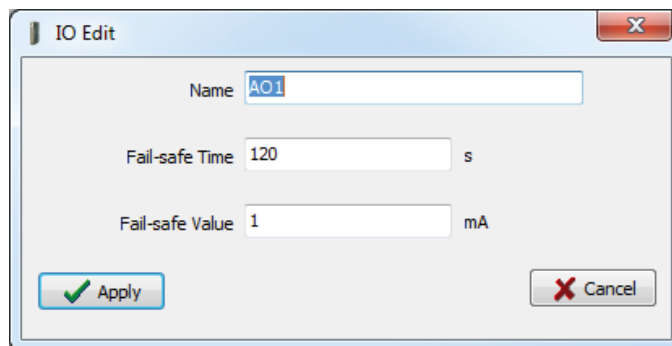

Figure 48 IO Edit (Analog Outputs)

The following parameters can be configured for 915U-2 analog outputs.

Name	Enter a name for the analog output or leave the default name. The name can be up to 30 characters, including spaces.
Fail-safe Time (sec)	<p>Sets the time the output needs to count down before activating the fail-safe state. Receiving an update or a COS message will reset the fail-safe timer to its starting value. When the fail-safe time elapses, the output is set to the fail-safe state (mA).</p> <p>It is recommend the fail-safe time be configured for a little more than twice the update time of the input that is mapped to it. That way the output will reset if it fails to receive two update messages. Entering a zero as the fail-safe time will disable fail-safe.</p>
Fail-safe Value (mA)	Sets the value that the output will be set to when the fail-safe time elapses.

Adding Expansion I/O Modules

Additional 115S serial expansion I/O modules can be connected to the 915U-2 module if more I/O is required. The RS-485 serial port on the 915U-2 is configured by default to communicate using the Modbus protocol. The default serial parameters of the RS-485 port on the 915U-2 are 9600 baud, no parity, 8 data bits, 1 stop bit, which match the defaults of the 115S serial expansion modules. These parameters can be changed, to increase poll speeds in larger systems, but the serial module's parameters must match that of the 915U-2 RS-485 port.

If more than three serial expansion I/O modules are added to the 915U-2 module, you will need to adjust the Maximum Connections setting for RS-485 or RS-232. To display these configuration screens, select the module in the project tree and click RS-485 or RS-232.

 **NOTE** Reducing the Maximum Connections setting will slightly improve the serial scan time. However, you need to make sure that the slave addresses fall within the Maximum Connections. If the Slave address is above the Maximum Connections, it will not be polled.

When you connect the serial expansion module, take note of the module address (the rotary switches on the bottom of the module). This address will be used as an offset to locate the I/O within the 915U-2. Also make sure that the termination switch is "on" (down) for the last module in the RS-485 loop.

 **NOTE** Failure to terminate the RS-485 correctly will result in modules not operating correctly.

115S Expansion I/O Memory Map

The I/O data on the 115S module is read into memory locations according to their Modbus address. The maximum number of Modbus addresses is 24. Each 115S module has an offset that applies to the location of its registers. This offset is equal to the units Modbus address (selected on the rotary switch on the end of the 115S expansion I/O module), multiplied by 20.

If the modules Modbus address is 15, the offset value will be $15 \times 20 = 300$.

For example, if connecting a 115S-11 (16 x DIO) with address #15:

- Digital input 1 will be at register location 10301
- Digital Output 1 will be at register location 301

If using a 115S-12 (8 x DIO & 8 AIN) with address 16:

- Digital input 1 will be at register location 10321
- Analog input 1 will be at register location 30321

For a detailed address map of the serial expansion I/O modules, see Appendix C.

When adding expansion I/O modules to the 915U-2, there are two inbuilt registers indicating the communication status of the expansion I/O module:

- Communication Fail—Located at register location 10019 + offset value. This register indicates “1” when the module is in failure.
- Communication OK—Located at register location 10020 + offset value. This register indicates “1” when the module is communicating properly.

Adding an Expansion I/O to MConfig

To add a 115S expansion I/O to the MConfig Utility, open the module in the project tree and click Expansion, and then click Add (see Figure 49).

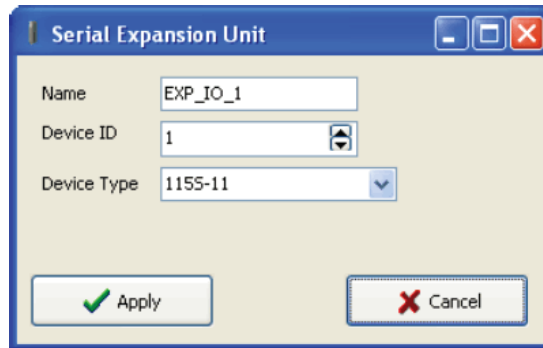

Figure 49 Serial Expansion Unit

Name	Enter a name for the 115S expansion I/O module, or leave the default name. The name can be up to 30 characters, including spaces.
Device ID	Select the address of the expansion I/O module. The address is found on the rotary switch on the bottom of the 115S expansion I/O module.
Device Type	Select the module type from the drop down list.

Fail-safe Blocks

To configure fail-safe blocks for a module, open the module in the project tree and click Fail-safe Blocks. The Fail-safe Block configuration screen (Figure 50) allows you to set registers to a pre-configured value on startup and configure the outputs to reset to a predefined value after a timeout period has elapsed. When the actual value is received, the register is automatically updated with this value. If the value is lost because of a communication problem, the register can be configured to set the output to a fail-safe value after the pre-configured time. You can have a maximum of 50 fail-safe blocks.

In the example shown in Figure 50, register 40501 holds an analog value that has been mapped from another module and is updated every 60 seconds. The fail-safe block is configured so that on startup the module will write a value of 16384 into register 40501, and then start counting down the fail timeout period (in this case, 130 seconds), which is a little over two times the update period from the sending module. If the module has not received an update from the other module after 130 seconds, register 40501 will be set to the fail value (in this case, 0). If the “Invalidate on Fail” option is selected, the value will be set to a null or invalidated value (~). If this register happens to be mapped to another module and the state is “Invalidated,” the mapping will be inhibited until the invalid value is updated with an actual value.

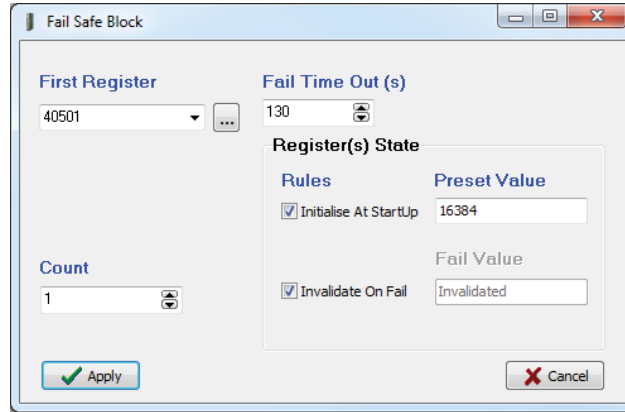

Figure 50 Fail-safe Block Analog

In the example shown in Figure 51, digital outputs 1–8 will be initialized on startup (turned on) and then start the fail timeout countdown from 60 seconds after which time the outputs will be set to the fail value (off) unless the output is updated.

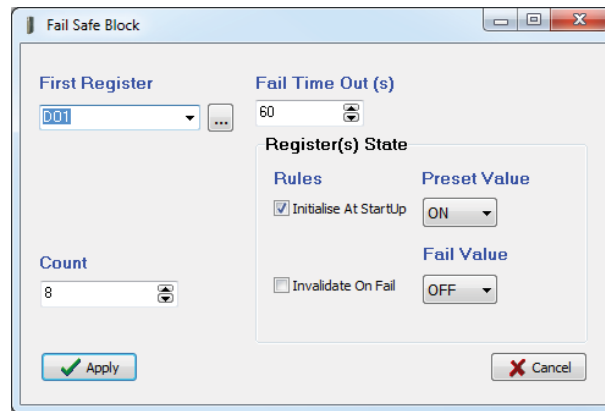



Figure 51 Fail-safe Block Digital

First Register	Starting register to which the fail-safe block applies.
Fail Timeout	Time period before the fail-safe state will be activated.
Count	Number of outputs to which the fail-safe block applies.
Initialize at Startup	Indicates the outputs will be initialized when the module is first powered on. Used in conjunction with the preset value.
Preset Value	Value the registers are set to when the module is powered on and the “Initialize at Startup” checkbox is selected. If a digital value is selected, the preset value will be either on or off. If an analog value is selected the preset value will be a value between 0 and 65535.
Invalidate on Fail	When selected, the value is set to a null or invalidated value (~) if an update is not received before the fail timeout period expires.
Fail Value	Value that the registers are set to if an update is not received before the fail timeout period expires and the “Invalidate on Fail” checkbox is not selected. If a digital value is selected the preset value will be either On or Off. If an analog value is selected the preset value will be a value between 0 and 65535.
Apply	Saves the settings.

Invalid Register State

All registers within the module can have different states, depending on the type of register and the type of value it holds. A typical analog range is between 0 and 65535, and a digital can be 0 or 1. Registers that are not associated with a physical I/O can also be in the “invalid” state, which means that the register has not been written to and holds a non-value or null value. For example, if you use I/O diagnostics to read the registers, an invalid register would read “~” as shown in Figure 52. For information on I/O diagnostics, see Chapter 5.

 **NOTE** Any mapping with an invalid register will be inhibited from sending. This is to ensure that the data sent to the destination is valid and not the default values the module has on startup. See “Fail-safe Blocks” on page 53 for information on configuring registers with a valid value at startup.

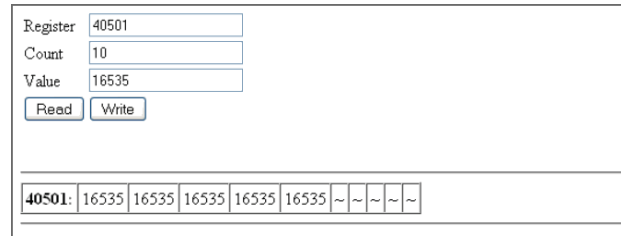

Figure 52 Invalid Register State

Sensitivity Blocks

All registers have a configurable sensitivity value that determines how much the register needs to change before a change-of-state” (COS) message is sent. All registers except the following have a default sensitivity value of 1:

- The 12 analog inputs have a sensitivity of 1000 bits, or approximately 3% (1000 bits from a total range of 32768 = 3.05%).
- The 24 floating point values have a default sensitivity of 0.5 units.
- Inputs 38001–38004 will be 0.5 mA, inputs 38005–38012 will be in volts, and inputs 38013–38016 will be in hertz.

A sensitivity value is needed for analog inputs in order to prevent the module from sending every single-bit change of an analog value, and subsequently saturating the radio channel with unwanted COS messages. If a lower sensitivity is required, the sensitivity block can be adjusted. However, care should be taken to not reduce the sensitivity to the point where radio messages are so frequent (due to a sensitivity change) that it saturates the radio network. There is a fine line between adjusting system parameters to receive up-to-date data and overloading the radio communications. A total of 50 sensitivity blocks can be configured for different registers or different values.

To change sensitivity blocks for a module, click Sensitivity Blocks in the project tree (see Figure 53). The screen lists existing sensitivity blocks for this module. To add a new sensitivity block, click Add. To edit an existing sensitivity block, select it in list on the right, and click Edit. This displays the IO Edit screen (see Figure 54) where you can change settings. To delete a sensitivity block, select it in the list and click Delete.

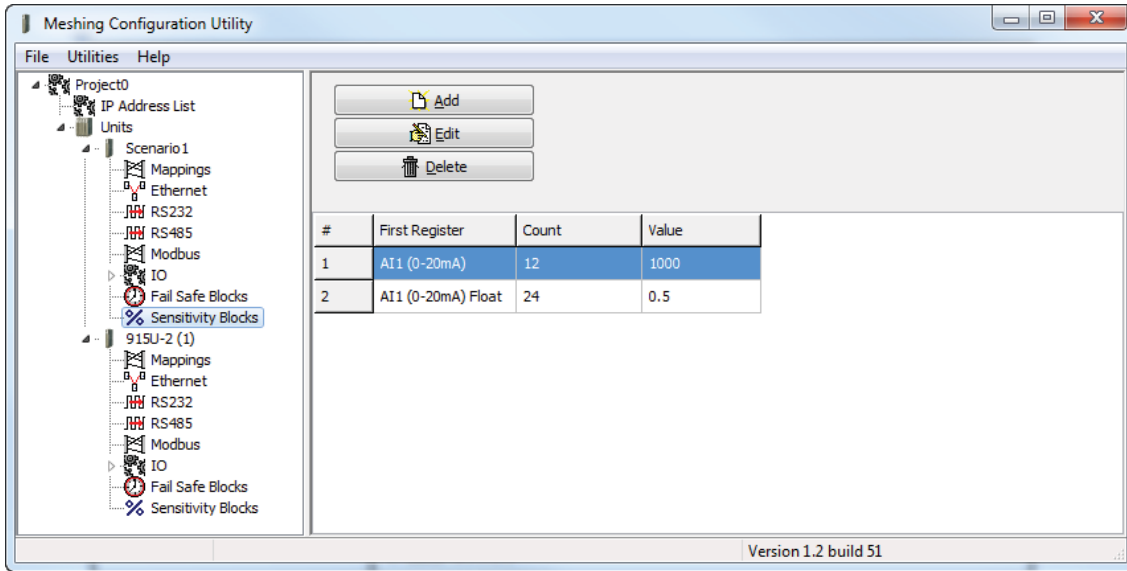

Figure 53 Sensitivity Block

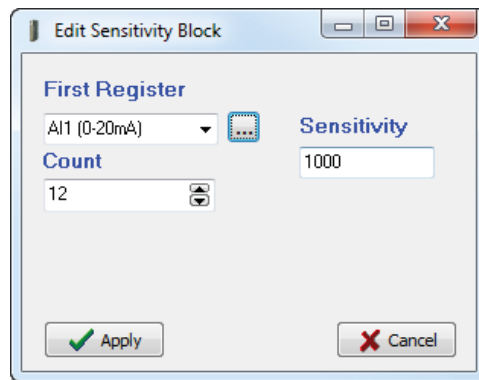



Figure 54 Editing Sensitivity Block

- First Register Select the starting register for the sensitivity block.
- First Register Select the actual register number within the register group range.
- Count Select the number of consecutive registers to which the sensitivity applies.
- Sensitivity Select the number of counts the register needs to change before a COS trigger occurs.

Serial Configuration

The 915U-2 module has an RS-232 and an RS-485 port for serial communications. These ports are used to connect ELPRO 115S-11, 115S-12, and 115S-13 serial expansion I/O modules. The ports can also be used to connect external Modbus RTU master or slave devices. The port operating mode and the normal serial parameters, baud rate, data format, flow control, and so on, all need to be selected from the drop-down lists, depending on the type of device connected and how it will operate.

 **NOTE** An error is displayed if the operating mode selection is incompatible with the configuration. For example, you will see an error if Modbus mode is not selected when Modbus mappings are configured.

Each serial port can be configured to operate in one of the following operating modes:

- Modbus RTU Master—This mode should be configured when the port is operating as a Modbus master, for example, when Modbus RTU slave devices are connected directly to the serial port.
- Modbus RTU Slave—This operating mode should be used when the port is being used as a Modbus RTU slave, for example, when a Modbus master (such as DCS, or SCADA) is connected to the serial port.
- Expansion I/O—This operating mode should be selected when ELPRO serial expansion modules are connected to the module.

Modbus RTU Master

To configure a module serial port as a Modbus RTU master, click the serial port (RS-485 or RS-232) in the project tree, and then select Modbus RTU Master from the Operating Mode drop down menu (see Figure 55).

The Modbus RTU master should be configured if the 915U-2 is acting as a Modbus RTU master and polling Modbus slave devices via the selected serial port. It also allows Ethernet Modbus/TCP clients connected to the 915U-2 Ethernet port to communicate with Modbus RTU slave devices connected to the configured serial port. The 915U-2 makes this possible by internally performing the necessary protocol conversion. The conversion is performed by the 915U-2 that is directly connected to the Modbus serial device (only this module needs to have Modbus TCP to RTU gateway enabled).

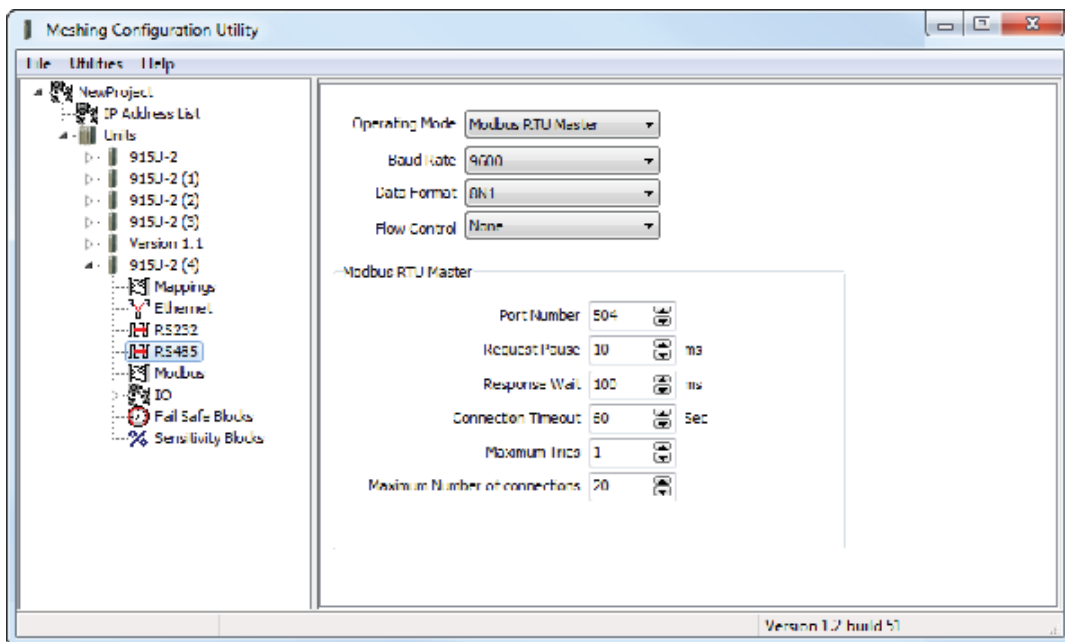

Figure 55 Modbus TCP/RTU

When a serial port is configured as a Modbus RTU master there are a number of parameters (such as baud rate, data format and flow control) that can be adjusted depending on the devices connected.

Port Number	TCP Port number configured for the serial port. A standard port number will be assigned, depending on the port. An RS-232 port is assigned 503, and an RS-485 port is assigned 504. Generally, these port numbers only need to be changed if the TSP client is using a non-standard port number.
Request Pause	Delay between serial requests, in milliseconds.
Response Wait	Serial response timeout period, in milliseconds. A serial retry is sent if a response is not received within this timeout period.

Connection Timeout	TCP connection timeout period, in seconds. If no Modbus/TCP data is received within this timeout period, the TCP connection will be dropped. Set this field to zero for no timeout.
Maximum Tries	Maximum number of request retries that are performed on the serial port.
Maximum Number of Connections	Maximum number of simultaneous TCP connections that can be made to the TCP server.

Serial Expansion I/O

To change serial port parameters for expansion I/O, click the serial port (RS-485 or RS-232) in the project tree, and then click Expansion I/O in the Operating Mode drop down menu (see Figure 56).

By default the RS-485 port is automatically enabled for expansion I/O. This is to allow you to connect serial expansion I/O modules with minimal or no module configuration. When you add an ELPRO Expansion I/O module (such as an 115S-11, 115S-12, or 115S-13) to the RS-485 port of the 915U-2, the I/O is automatically available from within the I/O store of the 915U-2. See Appendix E for location addresses, or refer to the 115S Expansion I/O User Manual.

The default data rate and data format are standard 9600, N81 with no flow control, which matches the default serial baud rate and data format of the 115S serial expansion module. Serial parameters can be adjusted for compatibility or faster serial performance. If you change the baud rate or data format, the serial port parameters on the expansion I/O module also need to be changed. To do this use the 115S Configuration Utility, which can be downloaded from the ELPRO Website at www.elprotech.com

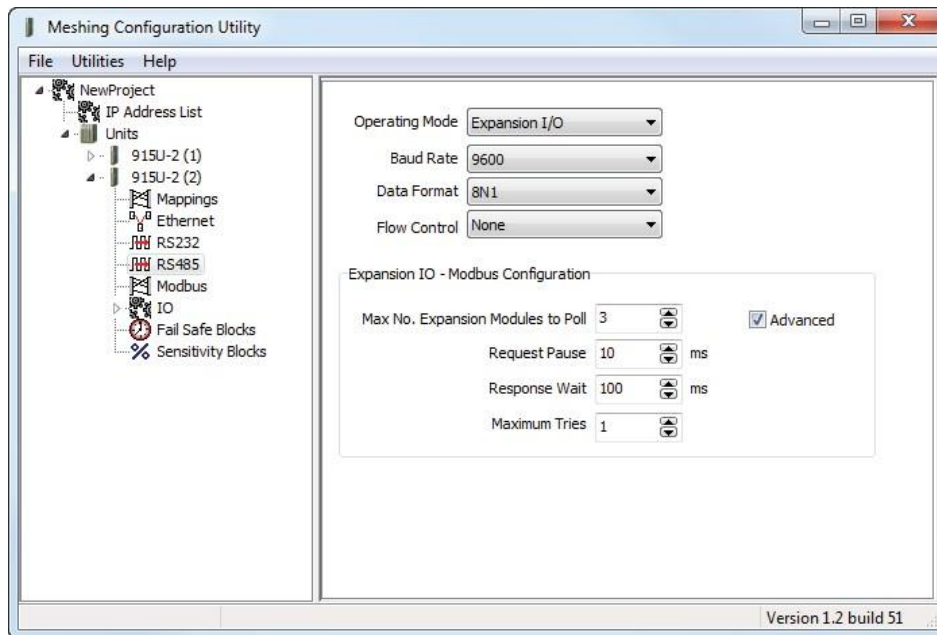

Figure 56 Expansion I/O

Maximum No. Expansion Modules to Poll	Maximum number of slave addresses that the 915U-2 will scan or poll. Default is 3. If adding more than 3 x 115S expansion I/O module or the address used are greater than 3, this number will need to be increased to match the largest address.
Maximum Number of Connections	Maximum number of simultaneous TCP connections to the server allowed.
Request Pause	Delay between serial requests, in milliseconds

- Response Wait Serial response timeout, in milliseconds. A serial retry is sent if a response is not received within this timeout period.
- Maximum Tries Maximum number of request retries performed on the serial port.

Serial Modbus RTU Slave

When a serial port is configured as a Modbus RTU slave, the only parameters that need to be configured are data rate, data format, and flow control. To configure these parameters, click the serial port (RS-485 or RS-232) in the module project tree, and then click Modbus RTU Slave in the Operating Mode drop down menu.

Modbus Configuration

The 915U-2 provides Modbus TCP client/server and Modbus RTU master/slave functionality for I/O transfer. Modbus TCP client, Modbus RTU master, and Modbus TCP server/RTU slave can all be supported simultaneously. When combined with the built-in Modbus TCP-to-RTU converter, the 915U-2 can transfer I/O to and from almost any combination of Modbus TCP or RTU devices.

The 915U-2 has predefined data areas for inputs and outputs and the different I/O types (bits, words, long, floats, and so on), which include the onboard input/outputs and are shared for both client and server. For a full list of the available I/O and address locations see Appendix B.

To change Modbus configuration parameters, click Modbus in the project tree. The Modbus configuration screen (Figure 57) is arranged in tabs. The main tabs are:

- Modbus TCP Server & RTU Slave—Used for configuring Modbus TCP Server or RTU Slave parameters.
- Modbus TCP Client & RTU Master—Used for any Modbus TCP Client and Modbus RTU Master Configuration parameters.

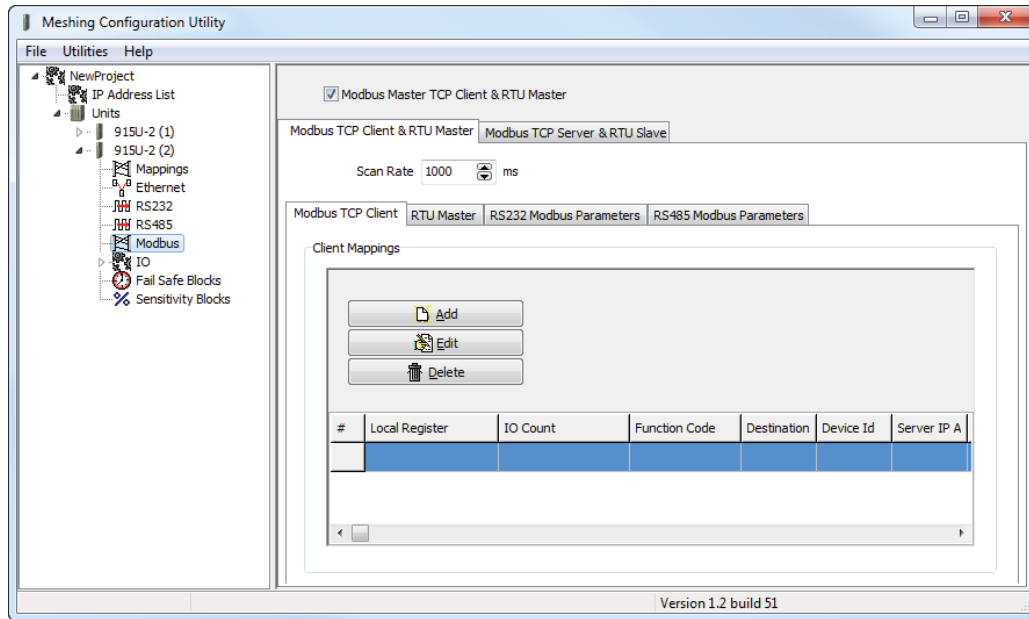

Figure 57 Modbus Configuration

Modbus Master TCP Client & RTU Master Used to enable the Modbus master TCP client and RTU master. When this is disabled the screen appears as in Figure 58

Scan Rate Allows you to adjust the Modbus polling scan rate

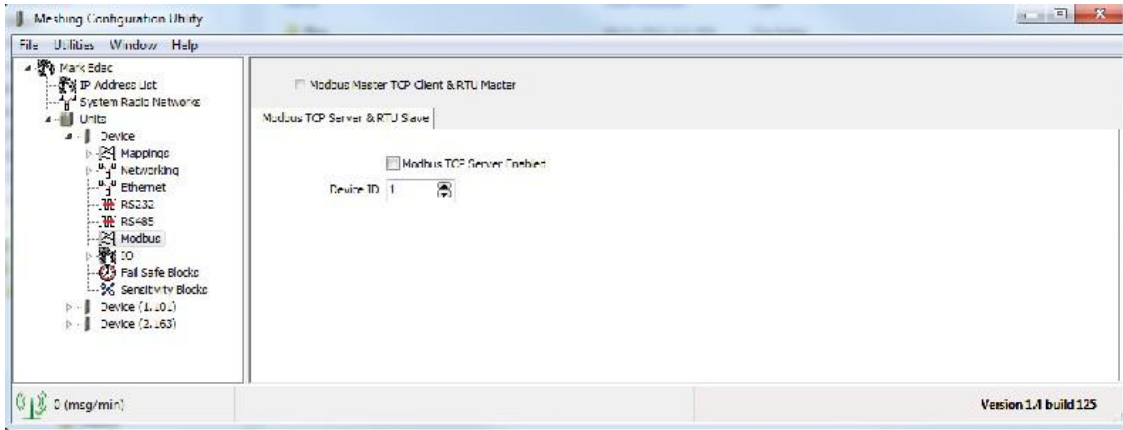

Figure 58 Modbus Master TCP Client & RTU Master Disabled

Modbus TCP Server and RTU Slave Tab

Click this tab in the Modbus configuration screen to change parameters for the Modbus TCP server or RTU slave (see Figure 59).

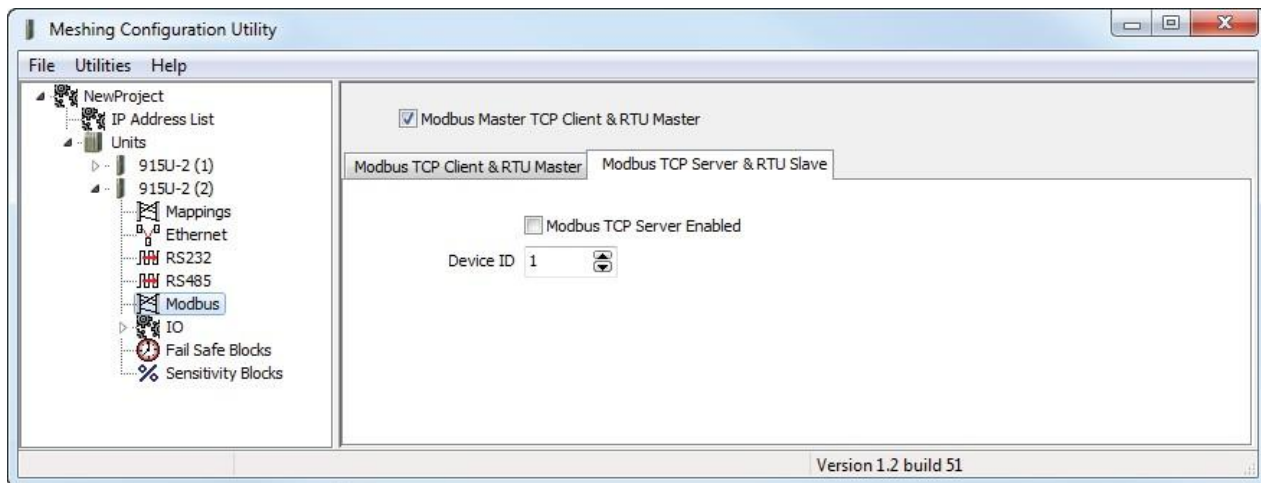

Figure 59 Modbus TCP Server & RTU Slave Tab

Modbus TCP Server enabled Allows the 915U-2 to accept connections from one or more Modbus TCP clients via Ethernet or RTU masters via the RS-485 or RS-232 serial interfaces. All Modbus transactions routed to the on-board Modbus TCP server/RTU slave are directed to/from the on-board general purpose I/O registers.

The Modbus TCP server is shared with the Modbus TCP to RTU converter, so that the Modbus device ID is used to determine if a Modbus transaction is to be routed to the on-board Modbus TCP server or to a Modbus RTU device connected to the serial port. Care should be taken to ensure that all serially connected Modbus devices use different device IDs (for example, Modbus slave address), and the device ID is different than the onboard device ID. Up to 32 separate connections to the Modbus TCP server are supported.

Device ID The device ID for the modules own Modbus server/slave. This is the ID that any external Modbus client or Modbus master would require to allow it to read values from the internal Modbus registers (for example, if a DCS or SCADA computer needs to poll the 915U-2 via TCP or serial connection).

Modbus TCP Client and RTU Master Tab

Click this tab in the Modbus configuration screen to set the Modbus client scan rate, which is common to both the Modbus TCP client and Modbus RTU master (see Figure 60). The default rate is 1000 msec. Each mapping is configured with a response timeout, which is the period of time that the master will wait for a response before indicating the failure on the Comms Fail Register.

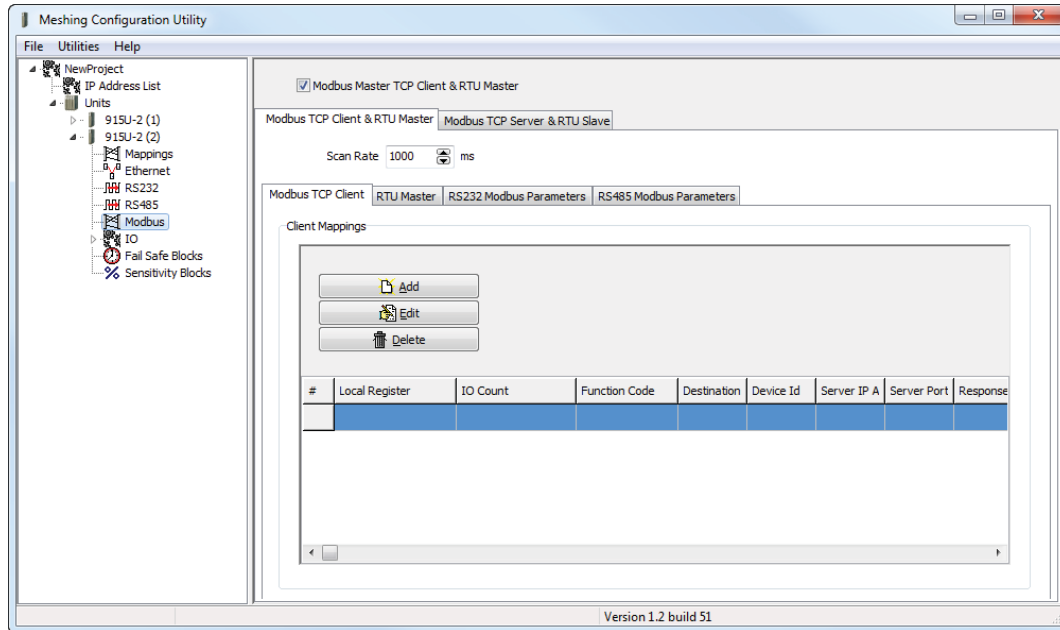

Figure 60 Modbus TCP Client & RTU Master Tab

The Modbus TCP Client and RTU Master tab contains the following subtabs.

- | | |
|--------------------------|---|
| Modbus TCP Client | Allows you to configure the Modbus client mappings to communicate with remote TCP devices. Modbus TCP client functionality allows connections to a maximum of 24 different Modbus TCP servers, and up to 100 mappings can be configured. For more information, see “Adding Mapping Parameters.” |
| RTU Master | Allows you to configure Modbus RTU mappings to communicate with remote serial Modbus devices. For more information, see “Adding Mapping Parameters.” |
| RS-232 Modbus Parameters | Shows the configuration parameters for RS-232 ports. See “RS-232/RS-485 Modbus Parameters” on page 64. |
| RS-485 Modbus Parameters | Shows the configuration parameters for RS-485 ports. See “RS-232/RS-485 Modbus Parameters” on page 64. |

All Modbus mappings are directed to and from the onboard I/O registers, depending on configuration (see the following section). The Modbus TCP client can poll Modbus TCP servers on either the local Ethernet network or over the WIBMesh radio network.

Adding Mapping Parameters

Before adding or modifying a module’s TCP or RTU mappings, make sure that the Modbus Master TCP Client & RTU Master checkbox is selected at the top of the Modbus configuration screen (see Figure 60). Click the Modbus TCP Client or the RTU Master subtab, depending on the connected device. Then, click Add to add a new mapping, Edit to edit a selected mapping, or Delete to delete a selected mapping. Clicking Add or Edit displays the screen in Figure 61, where you can specify mapping parameters.

Both Modbus TCP client and RTU master mappings have similar parameters, the only difference will be the slave communication path. For example, Modbus TCP client mappings will use a network address and port while RTU master mappings will use a serial port.

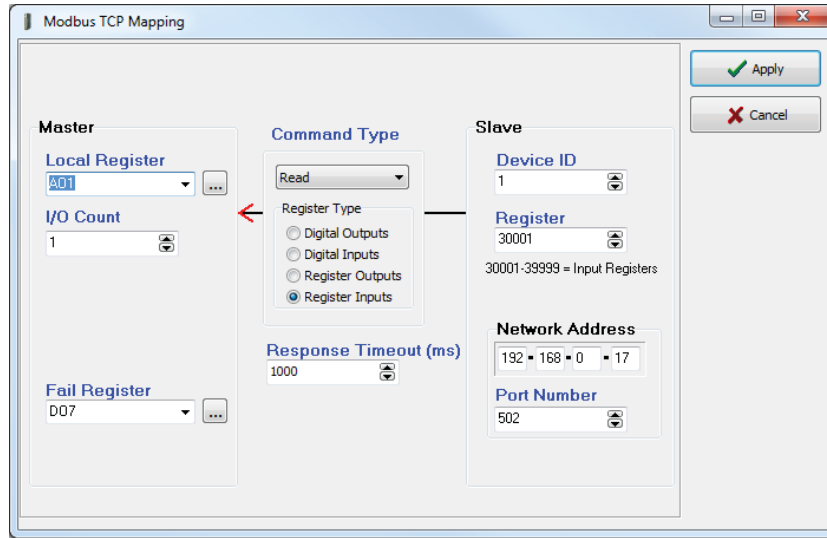

Figure 61 Modbus TCP Client Mapping

Local Register (Master)	When the Function Code Modbus command is “Read” the Local Register field will be the destination register (output location) on the local device. When the Function Code command is “Write” the Local Register field will be the originating register (input location) on the local device.
I/O Count	The number of consecutive I/O values in the mapping.
Function Code (Command Type)	The Function Code Modbus command determines if the command will be “Read” or “Write” and what type of register will be used. When entering a mapping, you need to select “Read” or “Write” from the drop-down list in the Command Type field, and then select one of the four radio buttons representing the register types. Selecting the register type will change the Destination (slave) register address range to a suitable range.
Destination Register (Slave)	The register location on the TCP server/RTU slave device. The register selection offered will be appropriate for the Modbus command selected in the Command field.
Device ID	The unit address (device ID) of the Modbus TCP server or Modbus RTU slave.
Server IP Address Network Address	(TCP client only.) The IP address of the Modbus TCP server.
Server Port (TCP Client only)	The server port of the slave device, Modbus TCP will usually be the standard port address of 502.
Serial Port (Modbus RTU only)	This is the serial port used to connect to the device. Select the port from the drop-down list.
Response Time	The amount of time the TCP client or Modbus master waits for a response from a TCP server or an RTU slave device before registering a Communications Fail.
Fail Reg	The Comms Fail indication register can be a physical output, such as DIO #1–8 (Reg 1-8), which will turn on a digital output when in fail. It can also be configured as an internal holding register (Reg 30501), which will show the fail indication as well as any Modbus error codes. This is useful for diagnosing communication problems. For Modbus error code descriptions, see Appendix D.

Modbus TCP Mapping Examples

In the example in Figure 62, the first mapping (#1) shows the Modbus client (master) is configured to read analog

values from a device connected to PROLANUT2 Wireless Mesh Controller and sending a count of four values (analog) from the Ethernet address 192,168.0.17, device ID #10, starting at address 30001, and then writing

these values into its own local registers, starting at 40501. The server port is 502, which is a standard Modbus TCP port address. If the mapping fails to communicate to the TCP server, it will write a value of “1” into local register 508, indicating a communications failure.

#	Local Register	IO Count	Function Code	Destination	Device Id	Server IP Address	Server Port	Response Timeout	Comm Fail Register
1	10501	1	Read	1	1	192.168.0.17	502	1000	DO8
2	AO1	1	Read	30001	1	192.168.0.17	502	1000	DO7
3	10502	1	Read	10001	1	192.168.0.17	502	1000	DO6
4	AO2	1	Read	40001	1	192.168.0.17	502	1000	DO5
5	10503	1	Read	10001	1	192.168.10.101	502	1000	DO4
6	10504	1	Read	10001	2	192.168.10.101	503	1000	DO3

Figure 62 Modbus TCP Mapping Table

The second mapping (#2) shows something similar, but instead of analog values, the values are digital. The Function code is “Read” from IP address 192.168.0.17 and device ID #10. It will read eight values starting from address 10001, and write them to the local address, starting at 501. Again, it is using the same server port of 502. If the mapping fails to communicate to the TCP server, it will write a value of “1” into local register 507, indicating that mapping failed to communicate.

The third mapping (#3) is similar to the second mapping, but instead of reading from the local Ethernet subnet (LAN) it is reading from an IP address on the radio network (another 915U-2 module). The Function code is “Read” from IP address 192.168.10.101 and device ID #1. It will read four values, starting from address 10001, and write them to the local address, starting at 509. A Comms Fail register is configured at local register 506.

The fourth mapping (#4) is configured to write the values from the local analog input #1 and #2 across to a TCP server at IP address 192.168.0.17. It will write the values into the destination address 40001 and 40002 at device ID of 10. It is using the TCP server port 502 and is configured with a response time of 1000 msec. If it fails to communicate, it will turn on local register 505.

Modbus RTU Master

Modbus RTU functionality allows connections to Modbus RTU slave devices via the RS-232 or RS-485 ports. The maximum number of mappings that can be configured is 100. All Modbus mappings are directed to or from the onboard I/O registers depending on the configuration (described below). The Modbus RTU master polls the slave devices via the serial port configured in the mappings.

Modbus RTU (serial) devices can also be polled if connected to remote 915U-2 serial ports. To enable this feature the remote 915U-2 serial port must be set to “Modbus RTU Master” mode and the TCP mappings must reflect the correct server IP address and port number of the remote 915U-2. Polling TCP servers or RTU slaves over the radio network will greatly increase radio communications and is not recommended for busy systems.

Example

The Modbus RTU mapping is very similar to the Modbus TCP mapping except that the destination is a serial interface instead of an Ethernet address and port.

In the example in Figure 63, the first mapping (#1) shows a read mapping from a serial device connected on the RS-485 port with a device ID of 5. It is reading one I/O point, starting at remote address 30001, and writing the value into the local address 40501. It is configured with a response timeout of 1000 msec, and local register 508 will indicate a failure to communicate with this device.

#	Local Register	IO Count	Function Code	Destination	Device Id	Serial Port	Response Timeout	Comm Fail Register
1	40501	1	Read	30001	5	RS485	1000	508
2	501	16	Read	10001	5	RS485	1000	507
3	VBatt	1	Write	40001	6	RS232	1000	506

Figure 63 Modbus RTU Example

The second mapping (#2) shows a read mapping from a serial device connected on the RS-485 port with a device ID of 5. It is reading 16 I/O points, starting at remote address 10001, and writing the value into the local address 501. It is configured with a response timeout of 1000 msec, and local register 507 will indicate a failure to communicate with this device.

The third mapping (#3) is a write mapping that will write the local battery voltage (Reg 30007) to register 40001 on a serial device connected on the RS-232 with a device ID of 6. Again, the response timeout is 1000 msec, and it has a communications fail register of 506.

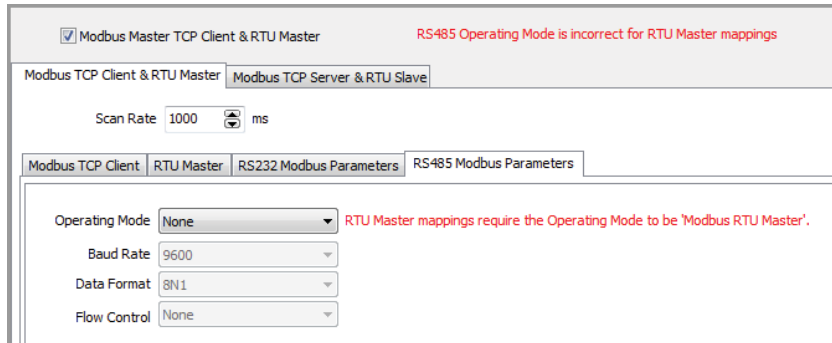

Figure 64 Operating Mode Error

! NOTE MConfig will indicate whether the serial port “Operating Mode” is not set, or set to the wrong mode. To change the mode, click the RS-232 or RS-485 Modbus Parameter tab.

RS-232/RS-485 Modbus Parameters

The RS-232 and RS-485 Modbus Parameters tabs show the configuration parameters for the RS-232 and RS-485 ports. These parameters are exactly the same as the serial parameters described in “Serial Configuration” on page 56. These parameters are displayed under the Modbus tab for convenience.

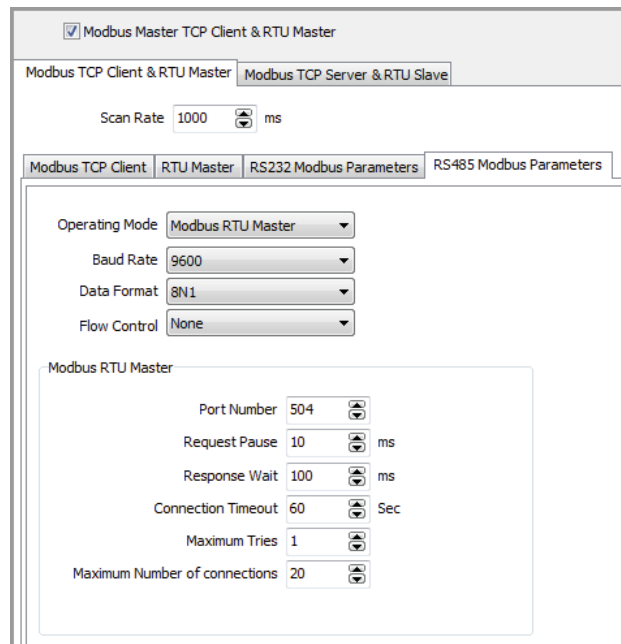

Figure 65 Modbus Parameters

4.3 Web-Based Configuration Utility

The 915U-2 module provides an embedded Web-based management utility that resides in flash memory on the module's CPU board. This utility allows you to manage wireless connection links between all 915U-2 modules in the system through a standard browser, such as Microsoft® Internet Explorer®. The utility supports Internet Explorer version 8.0 or later.



NOTE This section focuses on configuration and management tasks that can only be performed using the Web-based configuration utility. For all other configuration tasks, we recommend using the MConfig Utility for ease of use. MConfig is described in "4.2 MConfig Utility" on page 34.

Connecting and Logging On

The default IP address, subnet mask, gateway, username, and password for the 915U-2 module are as follows:

- IP Address: 192.168.0.1XX, where "XX" is the last two digits of the serial number shown on the printed label on the side of the module
- Subnet Mask: 255.255.255.0
- Default Gateway: 192.168.0.1
- Username: user
- Password: user

Follow these steps to connect and log on to the 915U-2 Web-based interface.

1. Follow the steps in "4.1 Connecting to the Module" on page 32 to connect the PC to the module.
2. Open Internet Explorer on the PC.
3. Type "http://" followed by the IP address of the module, and then press Enter.
4. If the PC uses a proxy server, ensure that Internet Explorer will bypass the proxy server for local addresses.
This option may be modified by opening Tools ->Internet Options ->Connections Tab -> LAN Settings -> Proxy Server -> bypass proxy for local addresses.
5. Type the username and password.
The home page appears (Figure 66).



IMPORTANT Remember to set DIP switch #6 to "off" and power cycle the module to return to normal operation after you have completed configuration. Otherwise, the module will continue to boot into the default IP address.

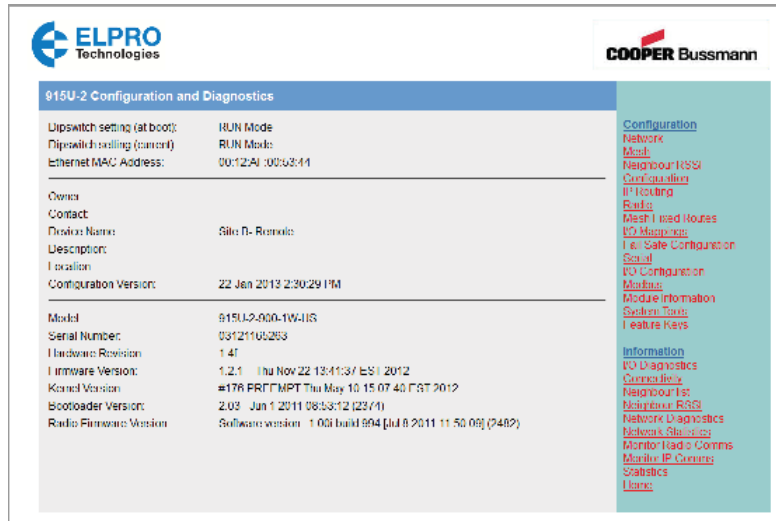

Figure 66 Home Page

Mesh Parameters

Click Mesh on the menu to changes parameters that govern wireless communication between all modules in the system.

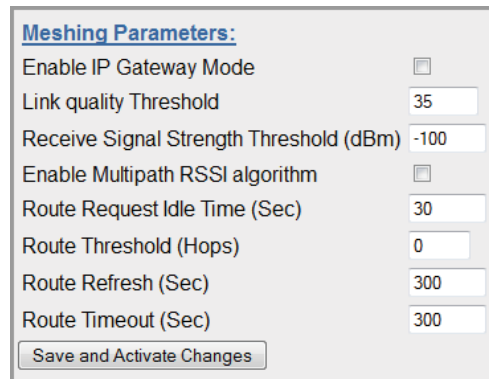

Figure 67 Mesh Configuration

Enable IP Gateway Mode

Enabling this option will allow communicating modules access to an external Ethernet Network if connected. The IP address range is configured by clicking Network on the menu. Care should be taken when enabling this option as it can increase overall network traffic. By default, this option is not selected (off) and should remain off unless there is an Ethernet network connected and other devices on the radio network need to communicate through this module to the external Ethernet network. All traffic for the external network must be routed through this IP address.

Link Quality Threshold

The radio will use this threshold level when establishing a mesh link with other radios in the system. It represents a 0–100% level of link quality (100 being the best). If the link quality is lower than the threshold, the link will be ignored. Link quality can be monitored on the Connectivity webpage. If the link quality is lower than this threshold, mesh routes will not be assigned over this link. Default value is 35.

Receive Signal Strength Threshold

The radio uses this threshold level when establishing a mesh link with other radios in the system. When establishing a mesh, the radio sends a broadcast message and then monitors the signal strength from all nodes that respond. If any of the signal levels are below the Receive Signal Strength Threshold, the mesh link will be ignored. The default threshold is –100 dBm, and is used in conjunction with the Link Quality Threshold.

Enable Multipath RSSI Algorithm	<p>This option should be enabled when the installation is in an environment that is known to have multipath fading. This typically occurs when units are installed in buildings or environments where the antennas do not have uninterrupted line-of-sight paths, or when there are large metallic objects close to the antennas.</p> <p>The multipath RSSI algorithm calculates a path RSSI that will be used when establishing mesh links between neighbors. The calculated link RSSI is compared to the configured RSSI threshold. If the calculated RSSI is stronger than the threshold, a link will be established.</p>
Route Request Idle Time (Sec)	<p>This sets how long the module will wait or hold off between route requests messages if the route request fails to reach its destination. The default time is 30 seconds, which means that if the module fails to communicate to its destination it will wait 30 seconds before sending out another route request. Without this wait time, a network might easily become swamped with route requests when a link fails to reach its destination.</p>
Route Threshold (Hops)	<p>This threshold configures the number of additional hops that the unit reports when replying to mesh routing requests. It can be used to configure a priority when a module is used as a repeater. For example, if two repeater modules are situated between a destination and the source, the repeater with the lowest route threshold will be used first.</p> <p>The default value is 0, which means the module will always act as repeater. Values between 1 and 7 will configure a priority, with higher numbers indicating units that are less preferred as repeaters. Setting the parameter to 8 means the unit will never be used as a repeater.</p>
Route Refresh (Sec)	<p>Sets how often the module will try to find a better (shorter) route for an existing route. This parameter is used where network topology changes can occur that might potentially allow a shorter path to be taken (for example, in a roaming or mobile application). Without route refresh, the existing route would continue to be used even though it may not be the best or most reliable link. The default value is 300 seconds. Setting this parameter to zero will disable the route refresh operation, and will mean that the existing route will never refresh except on module start up.</p>
Route Timeout (Sec)	<p>Sets the number of seconds that the route remains active after the last time it was used. When the timeout period expires, the route is deleted from the unit, and the module will need to rediscover what routes are available. Normally, the route timeout setting should be greater than the WIBMesh update time to a destination so that the routes will not time out and will remain active.</p>
Save and Activate Changes	<p>Saves changes to non-volatile memory and restarts the function to load the new configuration.</p>

Neighbor RSSI Configuration

RSSI values from neighboring devices can be stored in a register. Click Neighbor RSSI on the menu to map neighbor RSSI values to a register of your choosing. A maximum number of 100 neighbors can be configured, and any analog register can be used to store the value. The stored value will be a positive number between 40 and 120 that directly represents the receive signal strength. For example, a value of 72 represents -72 dBm.



NOTE Neighbor RSSI registers are only available when the module is configured in Meshing mode. For more information, see “Product Reconfiguration” on page 78.

Neighbour RSSI to Register Configuration:

Configure registers where the RSSI for the specified neighbour will be stored. The RSSI to the neighbour can then be mapped to another unit or read using Modbus.

Note: this does not change the operation of the radio mesh network.

Enable Neighbour RSSI to Register

#	Name	Neighbour IP	Register
1	192.168.10.101	192.168.10.101	30501
2	192.168.10.163	192.168.10.163	30502

Notes:
- A maximum of 100 neighbours may be configured.

Figure 68 Neighbor RSSI

- Enable Neighbor RSSI to Register Select this checkbox and click Save Changes to enable the neighbor RSSI registers.

- Add Entry Click to configure a new neighbor RSSI register. A new blank entry is added to the table. Enter the name, neighbor IP address, and register location, and click Save Changes.

- Delete Entry Click to remove a selected neighbor RSSI register configuration.

- Name A name that describes the neighbor (maximum 32 characters).

- Neighbor IP IP address of the neighbor module that you wish to monitor. The IP address should be the radio address of the 915U-2 module.

- Register The register location where the RSSI value will be stored.

- Save Changes Save changes to non-volatile memory. The module needs to be restarted for the changes to take effect.

- Save Changes and Reset Save settings to non-volatile memory, and reboot 915U-2. Once the module completes the reboot sequence, all changes are in effect.

IP Routing

Click IP Routing on the menu to change IP routing to other 915U-2 modules in other wired or wireless networks. When a 915U-2 module receives an IP frame that is destined for an IP address on a different network, it checks to see if the network address matches one of its own interfaces (hard-wired Ethernet, or radio) and forwards the frame appropriately. However, if the IP network address does not match the network address of any of its interfaces, the 915U-2 will forward the frame to its default gateway. In this case it is assumed that the default gateway has a valid route to the destination.

In some cases, such as routed wireless networks with more than two 915U-2 routers, it is not practical to have only one default gateway. If more than one next-hop router is required, the 915U-2 allows for the configuration of up to 100 routing rules. A routing rule specifies a destination network (or host) IP address and the corresponding next-hop router (gateway) to which messages for the specified destination will be forwarded. It is assumed that the gateway will then deliver the data to the required destination, or forward it on to another router that will.

Use Routing Rules to configure the next-hop router to use for a given destination host or network address.

IP Routing Rules:

Add Entry Delete Entry

#	Name	Destination	Netmask	Interface	Gateway	Enabled
1	Route #1	10.0.0.0	255.0.0.0	Any	192.168.0.1	<input checked="" type="checkbox"/>

Notes:

- Up to 100 routing rules can be configured.
- Name is a text label for the routing entry (Max 32 characters).
- Destination specifies the destination network (or host) IP address.
- Subnet Mask specifies the subnet mask for the destination network.
- Gateway specifies the IP address of the next-hop router for the specified destination.
- Gateway address is required only if Interface is set to Any

Save Changes Save Changes and Reset

Figure 69 IP Routing

- Add Entry** Click to add a new IP routing rule. A new blank entry is added to the table. Enter the information for the new rule, and click Save Changes.
- Delete Entry** Click to remove the selected IP routing rule.
- Name** Name describing the routing rule (maximum 32 characters).
- Destination** Destination network or host IP address. You can specify an entire network by entering the IP range 192.168.0.0 with a netmask of 255.255.255.0, or you can specify an individual host IP address by setting the netmask to 255.255.255.255.
- Netmask** Subnet mask for the destination network.
- Interface** The interface to use for the route. You can choose Radio, Ethernet, or Any.
- Gateway** Specifies the IP address of the next-hop router for the specified destination.
- Enabled** Select this checkbox to enable the routing rule. Deselect this checkbox to disable the routing rule without deleting it.
- Save Changes** Save changes to non-volatile memory. The module needs to be restarted for the changes to take effect.
- Save Changes and Reset** Save settings to non-volatile memory, and reboot the 915U-2 module. Once the module completes the reboot sequence, all changes are in effect.

Radio Settings

Click Radio on the menu to change radio configuration parameters for the 915-U-2. After changing settings, click Save and Activate Changes, and then reset the module for the changes to take effect.

Radio Settings:

Network Address 13446

Encryption Disabled

Encryption Key

Message Signature 0

Hopset Low

Transmit Power 30 dBm

Data Rate 19kbps

Disable Rx LNA

Notes:

- Network Address, Encryption and Message Signature must match for all stations in the same system
- Transmit power in conjunction with antenna gain should not exceed your country's maximum allowed EIRP
- Disable Rx LNA allows reduction of receiver sensitivity by 15dB. Used for demonstration where modules are physically close

Save and Activate Changes

Figure 70 Radio Configuration

Network Address	Unique address used to differentiate one wireless system from another. All radios required to communicate within the system need to have the same network address. Messages received with a different network address will be ignored. This prevents cross-talk between systems. Valid values are between 0 and 32768.
Encryption	Select 64-bit ELPRO proprietary encryption or 128, 192, or 256-bit AES encryption from the drop-down list.
Encryption Key	Up to 32 characters are available for the encryption key.
Message Signature	<p>The message signature is a section of data at the head of the radio message that contains a unique signature that the radio identifies with when receiving messages. Any message with a different signature is ignored.</p> <p>The selection varies by country. USA, Australia, New Zealand, and India have a selection of four signatures (0, 1, 2, 3). In Europe, 5 mW and 500 mW models have two options—Normal and Compatible. All modules must have the same message signature to successfully communicate.</p>
Hopset	The hopset or band is country-code specific. For example, US and Canada have two bands available—Low (902–914 MHz) and High (915–928 MHz). Australia, New Zealand and India have only one band (the country name is displayed in the field). European country codes indicate the configured frequency, for example, 869.525 MHz for a 5000-mW model, and 869.875 MHz for a 5-mW model.
Transmit Power Mode	You can adjust the transmit power level from 30 dB (1W) to 20 dB (100 mW). See the dBm to mW conversion table in Appendix A.
Data Rate	A selection of data rates is available, depending on the country code. Fixed frequency models (EU) can use 14, 38, 56, and 76 kbps. The FHSS (US, AU, NZ and IN) use 19, 56, 76, and 115 kbps. The communicating radio can be configured with a different data rate and will communicate at whatever rate is configured. The advantage of using the higher data rate is an increase in speed, but this is offset by a decrease in range.
Disable Rx LNA	Select this checkbox to disable the low noise amplifier (LNA). This reduces the receive sensitivity by about 15 dB. You may want to disable this option during demos, bench testing, or where there are close communication paths.
Save and Activate Changes	Save changes to non-volatile memory, and restart the function to load the new configuration settings.

Mesh Fixed Routes

A mesh fixed route is a route that has a fixed path through the mesh that will be used regardless of the signal quality. This means that communications are not rerouted if the signal quality is degraded. Setting up a mesh fixed route, requires that you configure the destination address, next-hop router address, and number of hops, and specify whether the destination is an IP gateway and whether it is external to the network.

In some radio systems, there will be a number of radios that will act as repeaters for other radios. Because these sites are generally stationary, they do not need to learn the different paths and can be configured to have fixed route paths back to the destination. You can configure these routes with mesh fixed route rules. Up to 100 fixed route rules can be configured for each site, and the rules can be targeted to a specific IP address by using a host route or a complete subnet.

To configure mesh fixed route rules, click Mesh Fixed Routes on the menu.



NOTE If you configure fixed routes and any part of the communication path fails (such as the path or module), there is no fallback to meshing.

Mesh Fixed Routing Rule Configuration

Use Routing Rules to configure the radio repeater paths between fixed repeater sites.

Mesh Fixed Routing Rules:

#	Name	Destination	Next	Hops	IP Gateway	External	Enabled
1	Fixed Site #1 to Gateway #1	10.0.0.1	10.0.0.1	1	<input checked="" type="checkbox"/>	<input type="checkbox"/>	<input checked="" type="checkbox"/>
2	Fixed Site #1 to Gateway #2	192.168.1.100	10.0.0.1	2	<input type="checkbox"/>	<input checked="" type="checkbox"/>	<input checked="" type="checkbox"/>

Notes:

- Up to 100 routing rules can be configured.
- Name is a text label for the routing entry (Max 32 characters).
- Destination specifies the destination host IP address.
- Next specifies the IP address of the next-hop router for the specified destination. Next is the same as Destination for the final hop.
- Hops indicates number of routing hops to the destination.
- Gateway indicates the Destination acts as a gateway out of the mesh.
- External indicates the route is through a gateway out of the mesh. For External Routes, Next is the gateway address to use.

Figure 71 Mesh Fixed Routes

- Add Entry** Click to add a new fixed routing rule. A new blank entry is added to the table. Enter the information for the new rule, and click Save and Activate Changes.
- Delete Entry** Click to remove the selected fixed routing rule.
- Name** A name that describes the routing rule (maximum 32 characters).
- Destination** The destination network or host IP address. You can specify an entire network by entering the IP range 192.168.0.0 with a netmask of 255.255.255.0, or you can specify an individual host IP address.
- Next** Specifies the IP address of the next hop router for the specified destination. The next hop router is the same as the destination for the final hop. For one-hop routes, the next hop router is the same as the destination.
- Hops** Indicates the number of routing hops to the destination.
- IP Gateway** When selected, the destination acts as a gateway out of the mesh.
- External** When selected, communications are routed through a gateway outside of the mesh.
- Enabled** Select this checkbox to enable the rule. Deselect this checkbox to disable the routing rule without deleting it.
- Save and Activate Changes** Save changes to non-volatile memory, and restart the function to load the new configuration settings.

Example #1

Normally, a meshing network will learn the routing paths within the network and set up a communication pathway to the destination, but some instances require you to create a fixed radio path. The network diagram in Figure 72 shows a basic network where the remote sites (#2, #3, and #4) all need to communicate back to Site #1 using fixed route paths rather than automatically meshing and finding their own path.

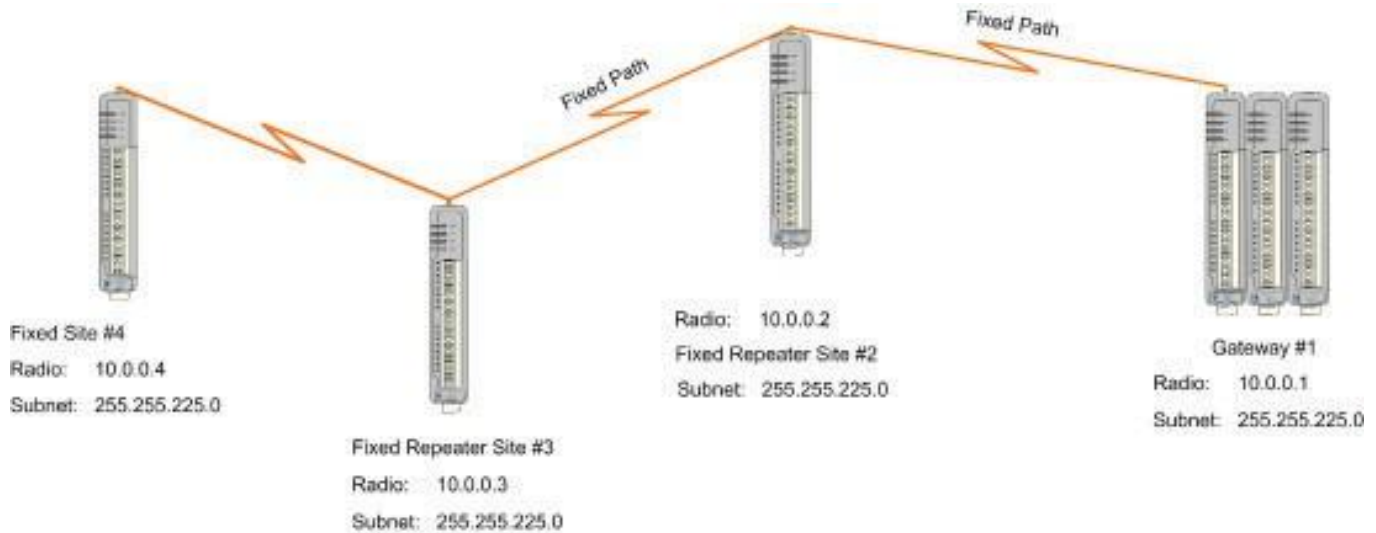

Figure 72 Mesh Fixed Route #1

Figure 73 shows the mesh fixed routing rules in the gateway for the network diagram in Figure 72. Entry #1 shows the destination IP address will be 10.0.0.2 (Repeater Site #2) and its next address will be itself (10.0.0.2). It is only one hop, and the "IP Gateway" and "External" checkboxes are deselected because the destination will be the local I/O on 10.0.0.2.

Entry #2 is similar to entry #1, except the destination address is 10.0.0.3 and the number of hops is two. The next address is 10.0.0.2 because all communications will pass through Repeater Site #2.

Entry #3 is also similar to entries #1 and 2, except the destination address is 10.0.0.4 and the number of hops is three. The next address will be the same as the other two routes because all communications will pass through 10.0.0.2.

Mesh Fixed Routing Rules:							
#	Name	Destination	Next	Hops	IP Gateway	External	Enabled
1	To Rep #2	10.0.0.2	10.0.0.2	1	<input type="checkbox"/>	<input type="checkbox"/>	<input checked="" type="checkbox"/>
2	To Site #3	10.0.0.3	10.0.0.2	2	<input type="checkbox"/>	<input type="checkbox"/>	<input checked="" type="checkbox"/>
3	To Site #4	10.0.0.4	10.0.0.2	3	<input type="checkbox"/>	<input type="checkbox"/>	<input checked="" type="checkbox"/>

Figure 73 Mesh Fixed Route - Gateway

Figure 74 shows the mesh fixed routes for Repeater Site #2. The first entry shows the communication path back to Site #1, therefore the destination IP and next address are configured with the address 10.0.0.1 (Site #1).

Because Site #2 is a repeater for Site #4, the second route shows the destination as Site #4, with Site #3 as the next address. The mesh fixed route configurations for the other remote modems will have similar routing rules, but the configuration will reflect the required communication paths.

Mesh Fixed Routing Rules:

Add Entry Delete Entry

#	Name	Destination	Next	Hops	IP Gateway	External	Enabled
1	To Site #1	10.0.0.1	10.0.0.1	1	<input type="checkbox"/>	<input type="checkbox"/>	<input checked="" type="checkbox"/>
2	To Site #4	10.0.0.4	10.0.0.3	2	<input type="checkbox"/>	<input type="checkbox"/>	<input checked="" type="checkbox"/>

Figure 74 Mesh Fixed Route - Repeater Site #2

After configuring all remote sites, you can check the communications paths by clicking Network Diagnostics on the menu, entering in the destination address in the “Remote IP Address” field, and then clicking Trace Route. In Figure 75, the trace route for the remote address 10.0.0.4 (Site #54) is communicating via 10.0.0.2 (Site #2) and 10.0.0.3 (Site #3).

Remote IP Address: 10.0.0.4 Count / Max Hops: 5 Ping TraceRoute

traceroute to 10.0.0.4 (10.0.0.4), 5 hops max, 40 byte packets

```

1 10.0.0.2 (10.0.0.2) 874 ms
2 10.0.0.3 (10.0.0.3) 685 ms
3 10.0.0.4 (10.0.0.4) 1373 ms
    
```

Figure 75 Trace Route

Example #2

Figure 77 shows the routing rules for the example in Figure 76. The first route indicates that the destination and next addresses are both 10.0.0.1, because it is a single hop. The destination is a gateway on an external network, therefore the IP Gateway checkbox must be selected. The second routing rule shows the destination (192.168.1.100) is an external network and is outside of the radio mesh, therefore the External checkbox must be selected. The next address will be 10.0.0.1, which is the IP gateway.

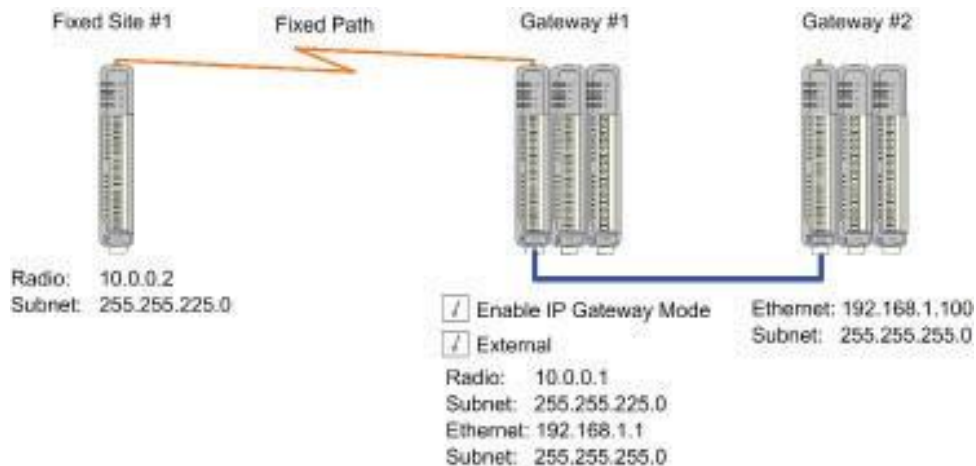

Figure 76 Mesh Fixed Route #2

Add Entry Delete Entry

#	Name	Destination	Next	Hops	IP Gateway	External	Enabled
1	Fixed Site #1 to Gateway #1	10.0.0.1	10.0.0.1	1	<input checked="" type="checkbox"/>	<input type="checkbox"/>	<input checked="" type="checkbox"/>
2	Fixed Site #1 to Gateway #2	192.168.1.100	10.0.0.1	2	<input type="checkbox"/>	<input checked="" type="checkbox"/>	<input checked="" type="checkbox"/>

Figure 77 Mesh Fixed Route #2 Routing Rules

Module Information Webpage

Click Module Information from the menu to change the following information for the module. With the exception of the password, the information entered here is displayed on the module's home configuration webpage.

Username	Username used to access configuration on the module. The default is "user". If you change the username, take care to remember the new name because you will need it to access the module in the future.
Password	Password used to access configuration on the module. The default is "user". If you change the password, take care to remember the new password because you will need it to access the module in future.
Device Name	Allows you to label the module. This is also the DNS host name given to the module if it is used with a DHCP client.
Owner	Module owner name.
Contact	Contact details can include a phone number, email address, and so on.
Description	Description of the module.
Location	Physical location of the module.
Configuration Version	Configuration version description.

System Tools

Click System Tools on the menu to perform administrative tasks, such as clearing the system log, reading or writing the module configuration, or performing firmware upgrades.

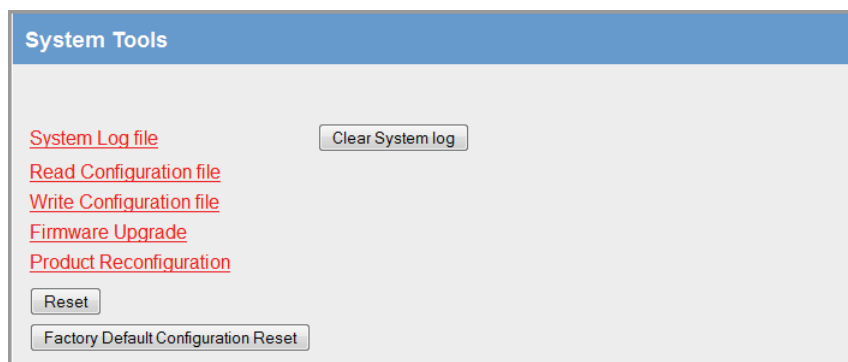



Figure 78 System Tools

System Log File	Logs system instructions and other information to the screen. The log screen can then be saved to a file that may be used by ELPRO technical support to diagnose problems.
Clear System Log	Clears the log screen.
Read Configuration File	Reads the module configuration to an XML file. This file can be saved by selecting "Save As" from the File menu.
Write Configuration File	Loads a previously saved XML configuration file into the module.
Firmware Upgrade	Upgrades the module firmware. For details, see "Patch File Firmware Upgrade" on page 75.

Product Reconfiguration	Switches the operating mode between WIBMesh and WIBNet. See “Product Reconfiguration” on page 78.
Reset	Resets the module.
Factory Default Configuration Reset	Resets the module and restores its factory default configuration.

Patch File Firmware Upgrade

To upgrade the module firmware locally using a firmware patch file, click System Tools from the menu, and then click Firmware Upgrade and browse for the saved firmware patch file. When you locate the file, click Send to upload the file to the module. A status message will appear. If the upgrade was successful, click Reset. If it was not successful, repeat the process. The module will verify that the file is valid before a reset can be initiated.

 **NOTE** All existing configuration parameters will be saved. However, if any new parameters are added to the firmware the default values will be used.

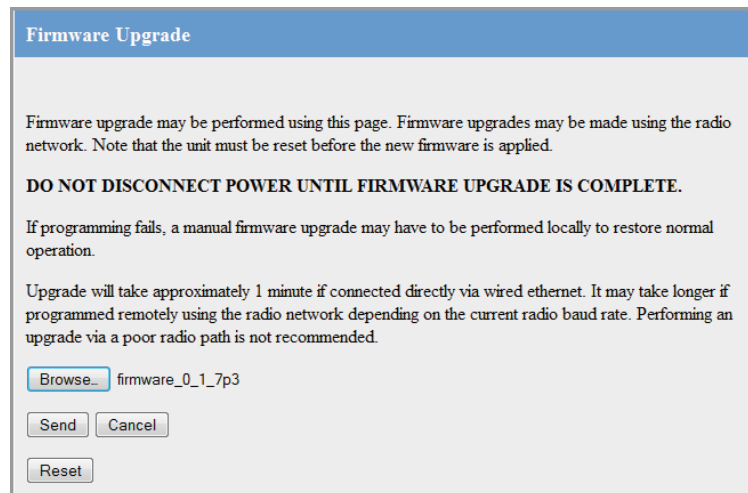



Figure 79 Firmware Upgrade

Full Firmware Upgrade

Firmware can also be upgraded using a USB flash drive containing the firmware files. A full USB upgrade is used if a patch file is not available or the existing firmware is a much older version and would require multiple patch files to upgrade to the latest version.

 **NOTE** The Modbus feature key and configuration is not changed or erased during a full upgrade. The following procedure provides instructions for performing a full USB firmware upgrade on a 915U-2.

Requirements

- USB flash drive
- Firmware files (contact ELPRO technical support for these files)
- Straight through Ethernet cable
- PC for transferring files

To prepare the USB flash drive

1. Plug the USB flash drive in to the PC. Right-click the drive and select Format from the menu.

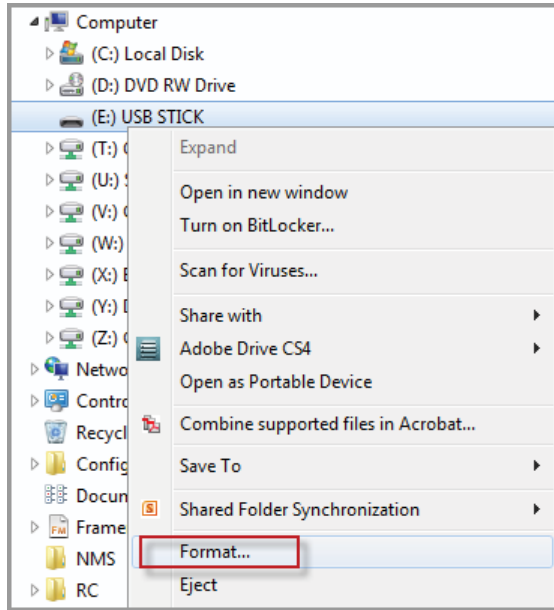

Figure 80 Formatting USB Flash Drive

2. Make sure that Quick Format is not selected, and then click Start.

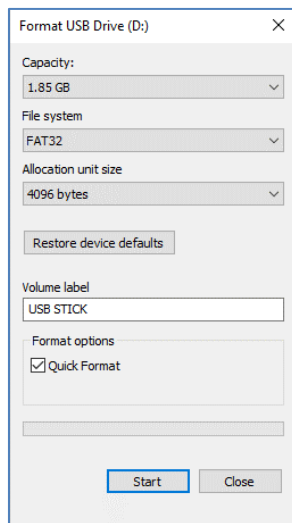

Figure 81 Quick Format

3. When formatting is complete, copy the supplied firmware files to the USB flash drive root directory. The files should look similar to Figure 82.

Name	Date modified	Type	Size
e2.jffs2.wrap	22/11/2012 1:41 PM	WRAP File	3,511 KB
e2.kernel.wrap	02/11/2012 3:10 PM	WRAP File	1,328 KB

Figure 82 Firmware Files

4. Remove the USB flash drive from the PC.

To perform a full firmware upgrade using USB flash drive

1. Connect to the module's Web-based configuration utility and make a note of the current firmware version, which appears on the home webpage.

This will enable you to compare versions to confirm that the upgrade procedure has been performed successfully.

Model:	915U-2-900-1W-US
Serial Number:	06101006038
Hardware Revision:	1.3a
Firmware Version:	1.1.3dev -- Wed Dec 15 12:02:19 EST 2010
Kernel Version:	#87 PREEMPT Tue Nov 16 16:56:26 EST 2010
Bootloader Version:	1.20 20100121
Radio Firmware Version:	Software version : 0.10o build 727 [built Nov 19 2010 11:31:03]

Figure 83 Firmware Version

2. Power off the 915U-2 if it is currently powered on.
3. Remove the cover from the small access panel on side of module to reveal a USB port and switches.



Figure 84 Module USB Port and Switches

4. Plug USB stick into USB port and power on the 915U-2 module.
5. The PWR LED will flash, as indicated in Figure 85.



NOTE Do not remove the flash drive or interrupt power to the module while the upgrade is in progress. If the upgrade process is interrupted, the module may become unserviceable and will need to be returned to ELPRO for repair.

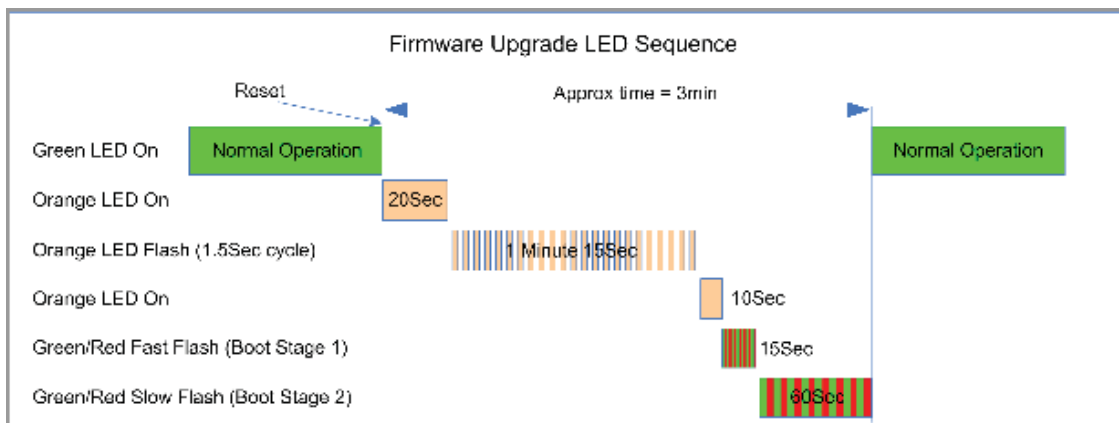



Figure 85 Firmware Upgrade LED Indicators

6. When the upgrade is complete, remove the USB flash drive from the module's USB port and replace the access panel cover.

Product Reconfiguration

WIBNet is a compatibility mode that will allow communications between the 915U-2 and earlier ELPRO E-Series Telemetry units, such as the 905U-1, 2, 3, 4, C, G, K, L, and so on.

 **NOTE** WIBMesh is the factory default operational mode for the 915U-2 module.

To change the operating mode between WIBMesh and WIBNet

1. Click System Tools on the menu, and then click Product Reconfiguration.
2. From the drop-down box (see Figure 86), select the from the following modes, and then click Set.
 - Meshing Mode—Standard ELPRO WIBMesh. This is the module’s factory default format.
 - Legacy Compatibility Mode—E-Series compatibility mode, will allow communications with ELPRO E-Series wireless I/O modules.
3. When prompted, click Reset Unit.

When the reset is complete, the module will be in the selected mode.

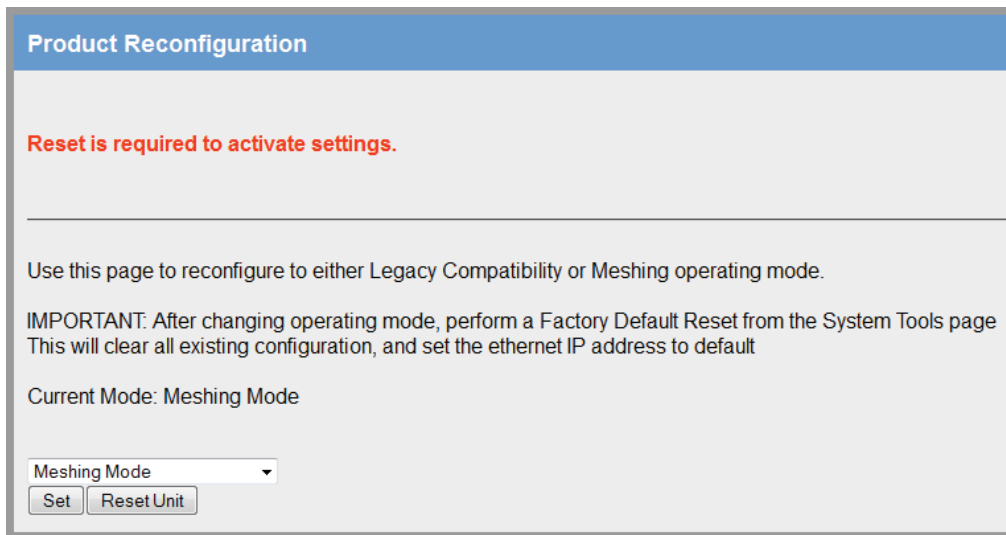

Figure 86 Product Reconfiguration

Feature License Keys

Feature license keys allow you to upgrade the 915U-2 module with enhanced features or to a more advanced model (for example, by enabling the Modbus option). The feature license keys can be purchased by contacting ELPRO Technologies or your local distributor. The module serial number is needed to generate the feature license key. The module serial number can be found on the home page (see Figure 66 on page 66).

You can temporarily enable all feature license options by placing the module in demonstration mode. This mode allows full operation of all feature licenses for 16 hours, or until the module is restarted.

To enter a feature license key or use Demonstration Mode, click Feature Keys in the menu.

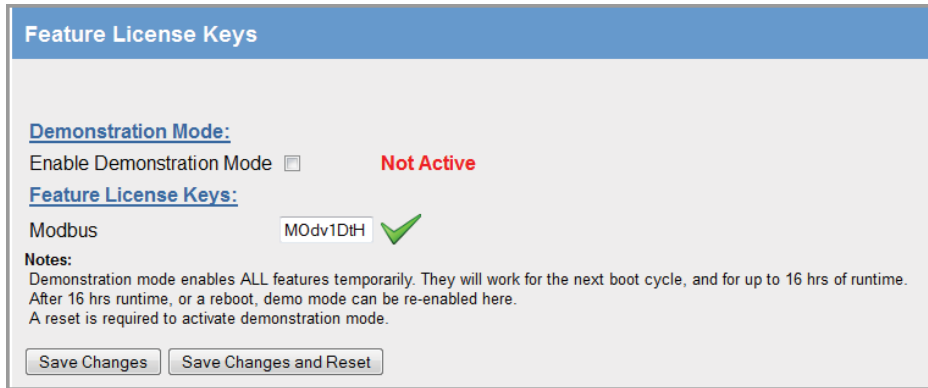

Figure 87 Feature Keys

Demonstration Mode	Selecting this checkbox and clicking Save Changes and Reset temporarily enables all feature license options for 16 hours (or until the unit is reset again). After the module resets, the message “Active” appears, indicating that the demonstration mode is activated.
Feature License Keys	Upgrades or advanced features are made available by entering the purchased feature license key into the appropriate box next to the feature or enhancement. After entering the code click Save Changes and Reset. If the code is valid, a green checkmark appears. If the code is invalid, a red cross appears. Feature license keys are retained even if the module is returned to factory defaults.

CHAPTER 5 - DIAGNOSTICS

This chapter describes network diagnostic tools and information available from the module's Web-based configuration utility. To access this utility, see "Connecting and Logging On" on page 65.

5.1 IO Diagnostics

Click IO Diagnostics from the home page of the Web-based configuration utility to read and write I/O store registers within the module.

To read a register location, enter an address location (for example, 10001 for digital inputs), enter a count (number of consecutive registers), and then click Read (see Figure 88). The returned address location and the returned values appears at the bottom of the page.

To write to outputs, enter the address location, count, and value, and then click Write. You will see the outputs change to the value you entered. For example, write to Register 1 with a count of 8 and a value of 1 will turn all the local digital outputs on. Write to Register 40001 with a count of 2 and a value of 49152 will set the two local physical analog outputs to 20 mA.

 **NOTE** If the value "~" appears at the bottom of the page when reading a register, it indicates that the register has not been written to and therefore has no value (not even zero).

A mapping will only be sent when all registers have a value. To set an initial value for registers upon startup, use the Fail-safe Block Configuration menu in the Web-based configuration utility or use the MConfig Utility (see "Fail-safe Blocks" on page 53). If there is a mapping configured and any one of the source register values has the value "~" the mapping will not be sent (see "Invalid Register State" on page 55).

Using the I/O Diagnostics page, you can check the register locations for the "~" values and even write values if required. If you see the value "3" when reading the status of the DIO on the module it indicates that the DIO is being used as an output in the "on" state.

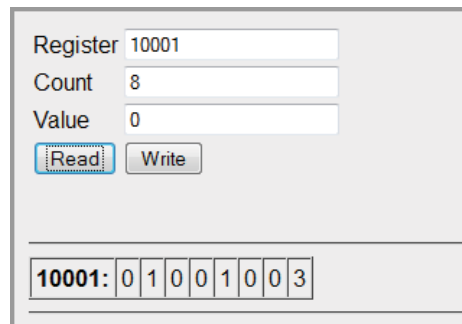

The screenshot shows a web interface for I/O Diagnostics. It has three input fields: 'Register' with the value '10001', 'Count' with the value '8', and 'Value' with the value '0'. Below these fields are two buttons: 'Read' and 'Write'. At the bottom of the interface, there is a display area showing the result of a read operation: '10001: 0 1 0 0 1 0 0 3'.

Figure 88 I/O Diagnostics

Register	Register address location.
Count	Number of consecutive registers, starting from the register location specified in the Register field.
Value	Value to be written.
Read	To read a register location, enter an address location (for example, 10001 for digital inputs), enter a count (number of consecutive registers), and then click Read.
Write	To write to outputs, enter the address location, count, and value, and then click Write.

Watchdog Error Log

The module uses a various processes to control aspects of its internal functions, such as radio operation, I/O functionality, AODV communications, and Modbus communications. Each process runs independently, and can interact with the other processes to provide a robust wireless I/O product.

All processes are monitored by an internal “watchdog.” If a processes has a problem and stops running, the watchdog will identify the problem and restart the process. The watchdog also creates a text file showing which process had the problem. This text file is stored in a directory called “dog” off the main root IP address of the module. To display this text file in your browser, enter <http://XXX.XXX.XXX.XXX/dog/>, where XXX.XXX.XXX.XXX is the IP address of the module.

If the watchdog directory continues to show text files, it may indicate a problem with the module or its configuration. If this happens, save the module configuration (see “System Tools” on page 74) and the list of watchdog files, and then contact ELPRO technical support.

The following table describes the different watchdog processes.

Watchdog Processes	
A00	Internal process monitor
A01	I/O processing application
A02	Fail-safe manager application
A03	Modbus application
A04	I/O mapping application
A06	AODV meshing protocol application
A07	Data logging application
A15	Warm restart backup

Module Information Registers

Certain registers in the module show modules characteristics, such as the serial number, firmware version, and so on. This information is available on the home page of the module’s Web-based configuration utility. However, having the information available in registers allows a host system to read the values via Modbus, if Modbus has been activated.

- Register 30494, 30495 and 30496 = Module serial number
- Register 30497, 30498 and 30499 = Module firmware version
- Register 30500 = Firmware patch level

Expansion I/O Error Registers

The 915U-2 has diagnostics registers allocated for each expansion I/O module. These registers indicate the module type, error counts, error codes, and so on. Each expansion I/O module has the following registers.

- 30017 + Offset = Modbus error counter (number of errors the modules has had)
- 30018 + Offset = Last 115S status code / Modbus error code

Register 30018 will display one of the following 115S status codes (hexadecimal code 1–5 and 129), as well as displaying Modbus response codes similar to what is shown in Appendix D, but with the most significant byte being one of the following values, 82, 84, 8F or 90.

Dec Code	Hex Code	Name	Meaning
1	0001	No Response	No response from a poll
2	0002	Corrupt/invalid	Corrupt or invalid data
3	0003	CRC Fail	CRC error check does not match the message. Indicates this a different message or possible data corruption.
4	0004	Response did not match request	The response heard was not the correct ID; possibly heard other RS-485 traffic.
5	0005	Message type did not match request	The response heard did not match the requested poll (different command response); possibly heard other RS-485 traffic.
81	0129	Problem accessing local memory	Could not access register location, possibly because the register is not initialized.
??01-??0B	Standard Modbus Error Codes	As per Appendix D	

- 30019 + Offset = Modbus Lost Link Counter (number of Communication Errors)
- 30020 + Offset = Modbus Module Type:
 - dec 257 (101hex) indicates a 115S-11
 - dec 513 (201hex) indicates a 115S-12
 - dec 769 (301hex) indicates a 115S-13

5.2 Mesh Connectivity

Click the Connectivity link from the home page of the Web-based configuration utility to display connections and available networks. The Connected Devices section on the Connectivity webpage displays the destination IP address, the relaying IP address, the number of hops the message is taking through the network, the signal strength and link quality, and message-related information. The readings shown are based on the last data message received from the device.

 **NOTE** When updating the Connectivity webpage, it may be necessary to hold down the <CTRL> key while pressing the refresh button to force your browser to refresh its cache.

<u>Connected Devices:</u>								
# Total entries: 4								
#	Dest	Next	Hops	RSSI	Qual	Flags	Iface	Age (H:M:S)
	192.168.2.107	192.168.2.107	1	-62	100		er0	00:00:03.3
	192.168.2.110	192.168.2.110	1	-85	100		er0	00:00:23.3
	192.168.2.102	192.168.2.108	3	~	~		er0	00:00:56.7
	192.168.2.108	192.168.2.108	1	-38	100		er0	00:00:56.7

Figure 89 Connectivity

- Dest Destination IP address.
- Next The next IP address used to reach the host.
- Hops Number of hops.

RSSI RSSI (received signal strength indicator) measured in dBm. This is a negative value scaled from -40 dBm (good) to -120 dBm (bad). RSSI is displayed for the destination addresses that are direct neighbors. If the destination IP is not the next hop, you will see an RSSI value of “~” which indicates no direct link to that station. If the Multipath RSSI option is enabled on the Mesh webpage, the RSSI will be a calculated RSSI value. If this option is disabled, the last known RSSI value is displayed.

Qual (Link Quality Indicator) A logarithmic representation of the number of bit errors in the frame that were corrected by the forward error correction algorithm. Each data bit is encoded with seven forward error correction bits. Therefore, a 100-byte frame contains 100 x 8 bits / byte x 7 FEC bits / bit = 5600 bits, as shown in the following table.

LQI	Description
100	No Errors (or better than 1 in 100,000)
80	1 in 10,000 raw bit errors
60	1 in 1000 raw bit errors
40	1 in 100
20	1 in 10

Flags Additional indications for this entry:

- G = Gateway (this unit is a gateway, providing access outside of the radio network)
- F = Fixed (this is a manually configured route)
- E = External (this unit a device outside the local network)

lface The connection interface (er0 = Ethernet radio, eth0 = Ethernet LAN).

Age (H:M:S) This is the timeout of the message in hours, minutes, and seconds.

Link Quality Indicator

Because a typical frame is around 80 bytes (4480 bits), you should not typically see link quality indicator (LQI) readings between 75 and 99. Communication becomes unreliable when the LQI drops to 30. As the LQI drops below 25, nearly every frame has so many bit errors that the FEC (forward error correction) is longer able to recover the original data and the frame will be corrupted. For this reason, you rarely see a reading below 25.

With a signal strength (RSSI) of -100 dBm or better, the LQI should always read 100. You can expect LQI readings below 100 with signal strength of -105 dBm or worse. If the signal strength is good and LQI readings are below 100, it indicates interference or a problem with the radio of the unit you are using.

5.3 Mesh Neighbor List

Click Neighbor List on the home page of the Web-based configuration utility to show a current list of module IP addresses that the radio can hear, the amount of time since a communication was last received from each address, and the calculated RSSI value. This page is useful for discovering the signal levels that the module has to other sites within the system, including ELPRO modules on different system addresses. The list displays all received radio messages, even if the message is not directly communicating to the module.

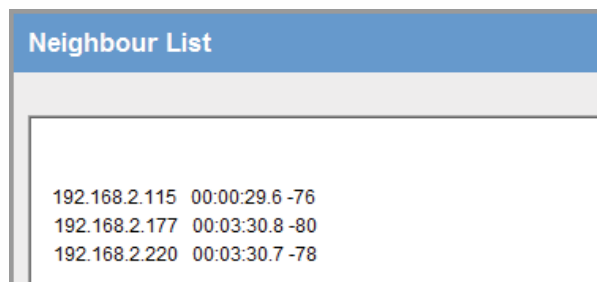

Figure 90 Neighbor List

5.4 Mesh Neighbor RSSI

Click Neighbor RSSI on the home page of the Web-based configuration utility to show the receive signal strength for each of the 50 available channels within the frequency band. To find out if the path between two neighboring units has a multipath fading issue, enter the radio IP address of the neighbor you want to view and click Get Graph. After the units have been running for a few minutes and passing radio data, the graph will fill with RSSI readings across all the radio channels in use. If the graph is nearly flat, there is no multipath fading between these units (see Figure 91). However, if the graph shows large dips (typically one or two) across several channels, there is multipath fading (see Figure 92).

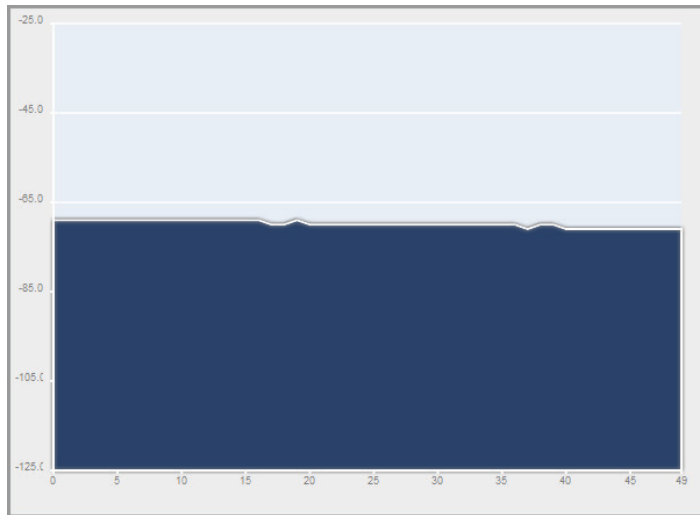

Figure 91 Neighbor RSSI - No Multipath Fading

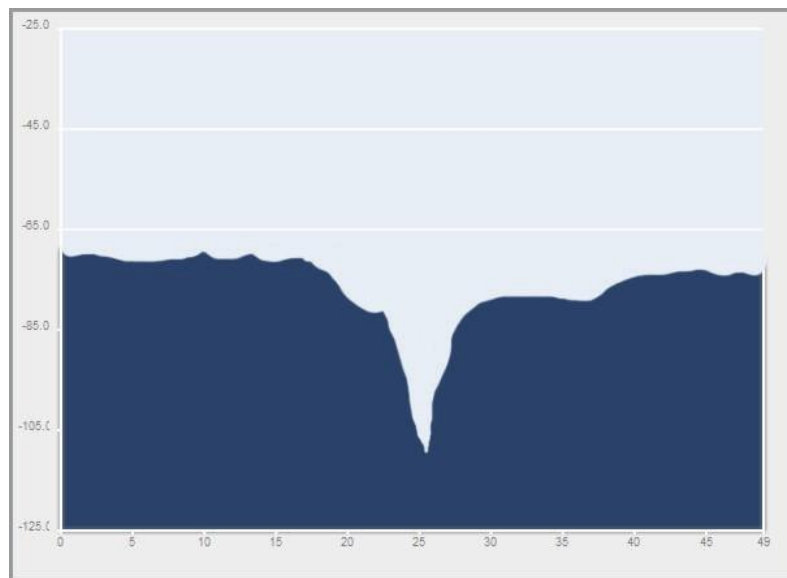

Figure 92 Neighbor RSSI - Multipath Fading

RSSI is gathered from the normal radio communications at the site. If communications is sparse, the graph may take time to fill all channels. If the graph is not filling after a long period of time, it may indicate a communications problem.

The multipath RSSI algorithm calculates a path RSSI that will be used when establishing mesh links between neighbors. The calculated link RSSI is compared to the configured RSSI threshold. If the calculated RSSI is stronger than the threshold, a link is established. Using this calculated path, RSSI ensures that radio data messages have the best chance of reaching the neighbor once a link is established, taking into account multipath fading. Once a

link is established between two units, the connectivity webpage also shows the calculated RSSI value.

5.5 Mesh Network Diagnostics

Click Network Diagnostics on the home page of the Web-based configuration utility to check the communications path to other modules within the system. There are two options for checking the communications—ping, and trace route, as described in the following sections.

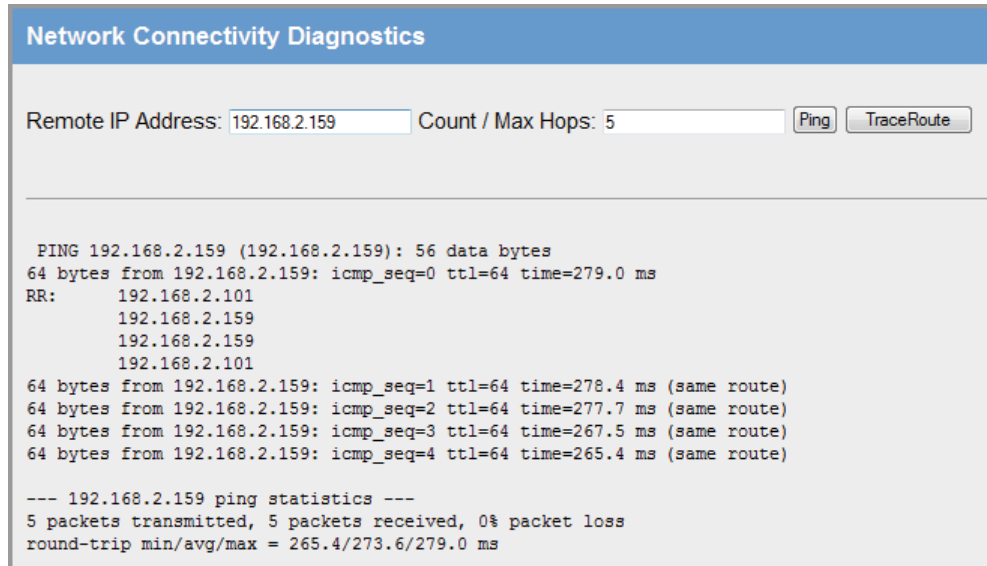

Figure 93 Network Diagnostics - Ping

Ping

Ping is a standard network instruction that sends a small data probe to the IP address configured, letting you know if there is a communication path. When you use the Ping option on the Network Diagnostics webpage (Figure 93) you will receive a response for each ping, which shows a packet size, IP address, sequence number, and a time (in milliseconds). This is followed by a summary showing the number of packets transmitted, the number of packets received, any lost packets, and the minimum, average, and maximum ping times (in milliseconds).

A ping can be performed on either the radio network or the Ethernet network. The ping command will automatically select the correct network interface according to the address selected. When pinging on the radio network, the response time for the first ping will be longer if the device needs to establish a network route to the destination. The information for the first ping shows the repeater path used.

Trace Route

Because the modules use the AODV routing protocol which is capable of finding its own path through the network, it can be difficult to determine the selected communications path. The Trace Route option on the Network Diagnostics webpage (Figure 94) allows the communications path to be traced through the network and determining how many hops the path is taking to get to the destination.

The example below shows the response time from the host to the first IP address (192.168.0.102) is 874 msec, the second IP address (192.168.0.106) is 685 msec and the third IP address (192.168.0.106) is 1373 msec. Each hop is a separate trace route discovery message from the host device to each remote IP address, and therefore the response times can vary as they are dependent on network lag times, throughput, interference, and so on.

Remote IP Address: Count / Max Hops:

traceroute to 10.0.0.4 (10.0.0.4), 5 hops max, 40 byte packets
 1 10.0.0.2 (10.0.0.2) 874 ms
 2 10.0.0.3 (10.0.0.3) 685 ms
 3 10.0.0.4 (10.0.0.4) 1373 ms

Figure 94 Network Diagnostics - Trace Route

Each trace route message has the following components.

1	192.168.2.108	(192.168.2.108)	874 ms
---	---------------	-----------------	--------

1 = Hop number

192.168.2.108 = DNS name of the device

(192.168.2.108) = IP address of the device

874 ms = A roundtrip response time (ping) in milliseconds from the Host IP to each hop point

5.6 Mesh Network Statistics

If you select the “Statistics Gathering” option on the Network configuration page (see Figure 95), you can then use the Network Statistics page to display the average receive and transmit throughput levels over a configured time period. On the Network Statistics page, select the sample period from the Stats Period menu and click Read to display the data (see Figure 96).

Network Configuration

Reset is required to activate settings.

Device Mode:
 Default Gateway

Ethernet Interface:
 Enabled
 MAC Address 00:12:AF:10:16:94
 Obtain IP Address Automatically
 IP Address
 IP Subnet Mask

Radio Interface:
 Enabled
 IP Address
 IP Subnet Mask

Enable Statistics Gathering

Figure 95 Network Configuration

Stats Period:

- Live
- Hourly
- Daily
- Weekly

Figure 96 Network Statistics Period

Stats Period

The sample period. Select one of the following options:

- Live—This option displays the average transmit and receive data through put in kbps and the number of data packets seen on the radio interface (er0), displayed in packet per minute. See Figure 97.
- Hourly— This option displays a graph showing overall transmit (t) and receive (r) data on an hourly scale in accordance with the module Date and time stamp. The letters “rt” indicate both transmit and receive. The table below the graph shows the average data throughput (in packets) for transmit and receive for each hour. See Figure 98.
- Daily or Weekly—These options show the average throughput over the daily or weekly time period. They also show the average number of packet received (rx) and Transmitted (tx) as well as the total. Average is an estimated value based on the amount of data gathered in the time available. See Figure 99.

Read

Displays statistics for the selected Stats Period.

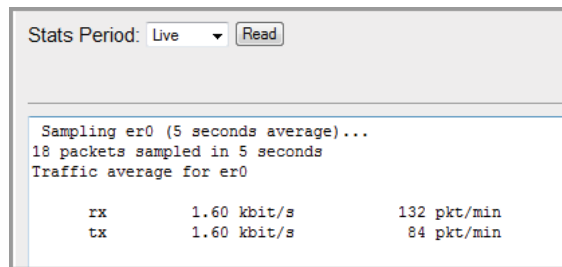

Figure 97 Live Statistics

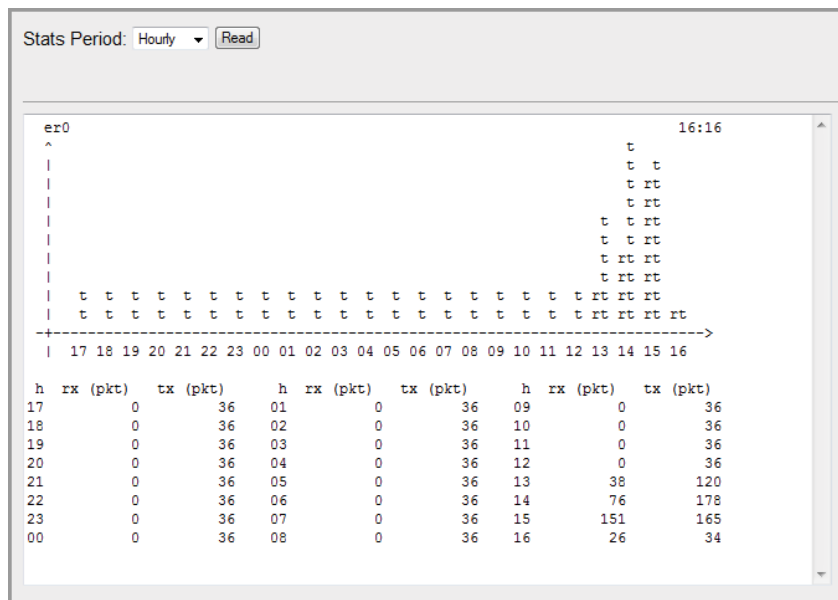

Figure 98 Hourly Statistics

Stats Period: Daily Read

er0 / daily

day	rx	tx	total	avg. rate
08/17/12	2242 pkt	2033 pkt	4275 pkt	3.0 p/min
08/18/12	7132 pkt	6445 pkt	13577 pkt	9.4 p/min
08/19/12	13139 pkt	12100 pkt	25239 pkt	17.5 p/min
08/20/12	170282 pkt	9734 pkt	180016 pkt	125.0 p/min
08/21/12	80466 pkt	1753 pkt	82219 pkt	57.1 p/min
08/22/12	4681 pkt	0 pkt	4681 pkt	3.3 p/min
08/23/12	3708 pkt	422 pkt	4130 pkt	2.9 p/min
08/24/12	4629 pkt	90 pkt	4719 pkt	3.3 p/min
08/25/12	104792 pkt	1768 pkt	106560 pkt	74.0 p/min
08/26/12	218043 pkt	309 pkt	218352 pkt	151.6 p/min
08/27/12	245391 pkt	20353 pkt	265744 pkt	184.5 p/min
08/28/12	263575 pkt	63350 pkt	326925 pkt	227.0 p/min

Figure 99 Daily/Weekly Statistics

5.7 Monitor Communications

Monitor WIBMesh Radio Communications

Click Monitor Radio Comms on the home page of the Web-based configuration utility to view communication frames that are received or transmitted by the radio (Figure 100).

 NOTE Corrupted data frames are shown with an "ERROR!" in the frame.

Monitor Radio Communications

```

16:05:49.770 Rx : * 907.625 57dBm [ 10] 80 6D 34 86 02 65 02 9F 08 00
16:05:49.844 Rx : * 912.375 56dBm [ 72] 80 92 34 86 02 65 02 9F 08 00 ...
16:05:49.859 Tx : - 912.375 [65535] [ 10] 80 52 34 86 02 9F 02 65 08 00
16:05:49.928 Tx : * 912.875 [ 1071] [ 62] 80 AE 34 86 02 9F 02 65 08 00 ...
16:05:49.943 Rx : * 912.875 56dBm [ 10] 80 6E 34 86 02 65 02 9F 08 00
16:05:50.755 Tx : * 908.875 [ 1072] [ 74] 80 AF 34 86 02 9F 02 65 08 00 ...
16:05:50.770 Rx : * 908.875 56dBm [ 10] 80 6F 34 86 02 65 02 9F 08 00
16:05:50.844 Rx : * 909.875 56dBm [ 72] 80 93 34 86 02 65 02 9F 08 00 ...
16:05:50.858 Tx : - 909.875 [65535] [ 10] 80 53 34 86 02 9F 02 65 08 00
16:05:50.927 Tx : * 911.125 [ 1073] [ 62] 80 B0 34 86 02 9F 02 65 08 00 ...
16:05:50.942 Rx : * 911.125 56dBm [ 10] 80 70 34 86 02 65 02 9F 08 00
16:05:51.596 Rx : * 909.875 115dBm [ 7] ERROR! #0x80228011
16:05:51.756 Tx : * 911.875 [ 1074] [ 74] 80 B1 34 86 02 9F 02 65 08 00 ...
16:05:51.771 Rx : * 911.875 57dBm [ 10] 80 71 34 86 02 65 02 9F 08 00
16:05:51.845 Rx : * 906.125 61dBm [ 72] 80 94 34 86 02 65 02 9F 08 00 ...
16:05:51.860 Tx : - 906.125 [65535] [ 10] 80 54 34 86 02 9F 02 65 08 00
16:05:51.929 Tx : * 908.625 [ 1075] [ 62] 80 B2 34 86 02 9F 02 65 08 00 ...
16:05:51.944 Rx : * 908.625 57dBm [ 10] 80 72 34 86 02 65 02 9F 08 00
16:05:52.758 Tx : * 913.375 [ 1076] [ 74] 80 B3 34 86 02 9F 02 65 08 00 ...
16:05:52.773 Rx : * 913.375 55dBm [ 10] 80 73 34 86 02 65 02 9F 08 00
16:05:52.846 Rx : * 912.125 56dBm [ 72] 80 95 34 86 02 65 02 9F 08 00 ...
16:05:52.861 Tx : - 912.125 [65535] [ 10] 80 55 34 86 02 9F 02 65 08 00
16:05:52.930 Rx : * 909.625 [ 1077] [ 62] 80 B4 34 86 02 9F 02 65 08 00 ...
16:05:52.945 Rx : * 909.625 56dBm [ 10] 80 74 34 86 02 65 02 9F 08 00
16:05:53.757 Tx : * 913.875 [ 1078] [ 74] 80 B5 34 86 02 9F 02 65 08 00 ...
16:05:53.772 Rx : * 913.875 57dBm [ 10] 80 75 34 86 02 65 02 9F 08 00
16:05:53.846 Rx : * 907.125 62dBm [ 72] 80 96 34 86 02 65 02 9F 08 00 ...
16:05:53.861 Tx : - 907.125 [65535] [ 10] 80 56 34 86 02 9F 02 65 08 00
16:05:53.930 Tx : * 905.625 [ 1079] [ 62] 80 B6 34 86 02 9F 02 65 08 00 ...
16:05:53.945 Rx : * 905.625 68dBm [ 10] 80 76 34 86 02 65 02 9F 08 00
    
```

Start Stop Clear Buffer Size: 3000

Figure 100 Monitor Radio Comms

The following table describes two data frames from the communications log screen in Figure 100.

Time	TX/RX	Frequency	Signal Level	Data Length	Data
16:05:51.756	Tx :	911.875	[1074]	(74)	80 B1 34 86 02 9F 02 65 08 00
16:05:51.771	Rx :	911.875	-57dBm	(10)	80 71 34 86 02 65 02 9F 08 00

- Time Time since the module was turned on.
- TX/RX Indicates whether the message is received or transmitted.
- Frequency Radio frequency of the RX/TX frame.
- Signal Level Shows the receive signal level on any received message or internal sequence number for the transmitted message.
- Data Length Total length of the transmitted or received message.
- Data The TX data frame in the example contains the following:
 - First two bytes (80 B1) = Frame flags
 - Second two bytes (34 86) = Network address
 - Third two bytes (02 9F) = Destination address, (FFFF is a broadcast address)
 - Fourth two bytes (02 65) = Source address (convert each byte to decimal and they will be the last two bytes of the radio IP address)
 - Fifth two bytes (08 00) = Ether type flag (Internet Protocol, Version 4)

Monitor WIBMesh IP Comms

Click Monitor IP Comms on the home page of the Web-based configuration utility to view the IP communication data frames. From here you can decode the ELPRO data frame and read the transmitted and received I/O values.

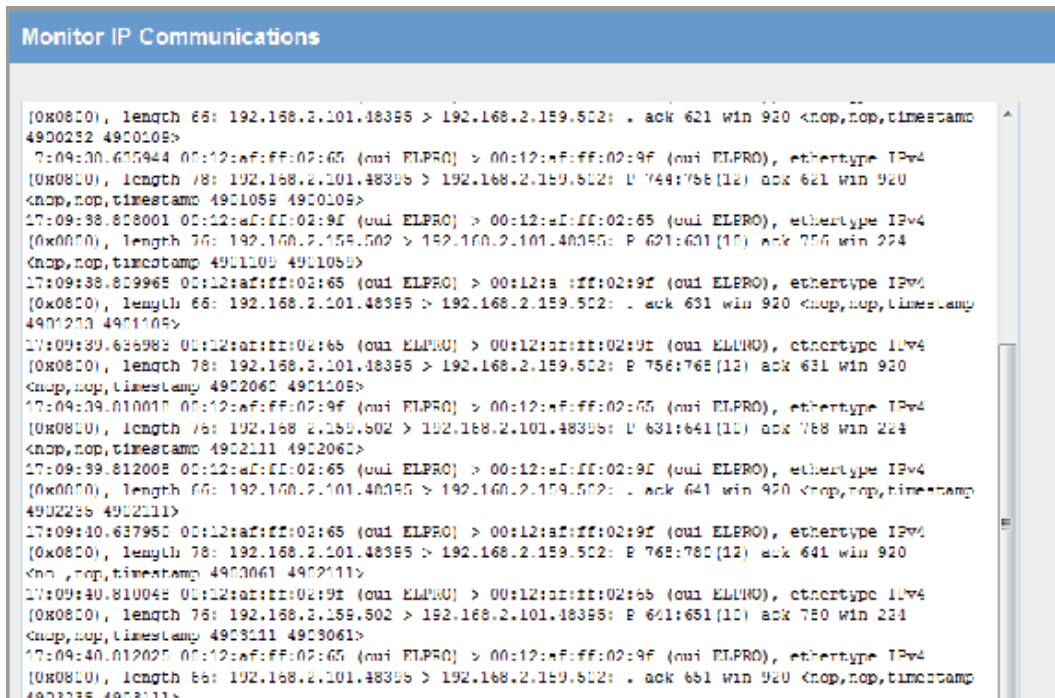

Figure 101 IP Communication Monitoring

The following table describes two data frames from the communications log screen in Figure 101.

Time	Source IP	Dest IP	Len	Type	Seq	Ack	Dest	Cnt	Val
03:02:45.073629	192.168.2.146.51891	192.168.2.143.4370	7	WRITE	9		1	1	11111110
03:02:45.075693	192.168.2.143.56678	192.168.2.146.4370	1	ACK	9				

- Time Message time stamp (the time since the module was last started).
- Header Indicates whether the message is a receive (In) or a transmit (Out) message, as well as the type and size of the Ethernet frame.
- Source IP Originating or source IP address.
- Dest IP Destination IP address.
- Len Total length of ELPRO data .
- Type Type of message, for example, Write, Read, Gather/Scatter, and so on.
- Seq Sequence number of the message.
- Ack Indicates whether the ELPRO data frame is configured to acknowledge or not acknowledged. This is configured in each mapping.
- Dest I/O address at the destination. The destination is the location that the data will be written to or read from.
- Cnt Total I/O count from the address in the Dest field.
- Val Data values. The number of values will depend on the I/O count.

Monitor WIBNet Radio Comms

If you have reconfigured the 915U-2 to use the legacy WIBNet protocol, you can click Monitor Comms on the home page of the Web-based configuration utility to view the received and transmitted WIBNet data frames. For information on reconfiguring the 915U-2 for legacy WIBNet protocol, see “Product Reconfiguration” on page 78.

 NOTE Corrupted data frames are shown with an “ERROR!” in the frame.

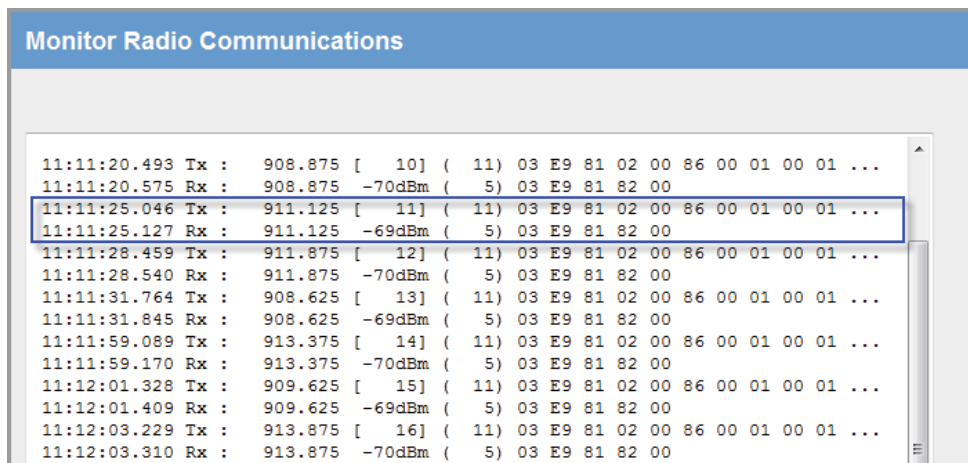

Figure 102 WIBNet Monitor Comms

The following table describes two data frames from Figure 102.

Time	TX/RX	Frequency	Signal Level	Data Length	Data
11:11:25.046	Tx :	919.125	[11]	(11)	03 E9 81 02 00 86 00 01 00 01 ...
11:11:25.127	Rx :	921.125	-69dBm	(5)	03 E9 81 82 00

Time	Time since the module was turned on.
TX/RX	Indicates whether the message is received or transmitted.
Frequency	Shows the frequency of the RX/TX frame.
Signal Level	Shows the receive signal level on any received message or internal sequence number for the transmitted message.
Data Length	Total length of the transmitted or received message.
Data	The TX data frame in the example contains the following:

First two bytes (3A 03) = System address

Next 1 to 5 bytes (dynamic) = Unit address and any repeater addresses.
 As the message gets passed to the next address the address gets 128 dec (80 hex) added to it, indicating that the message has passed through the repeater or been received and acknowledged. As shown in the above example, the fourth byte of the transmitted message is 02, which changes to 82 on the received message and indicates the acknowledgment from the receiving module.

Fifth byte (00) = Zero byte spacer

Sixth byte (86) = Frame flag (type of message)

The rest shows the message count and values. For a full breakdown of the protocol, contact ELPRO Technologies.

5.8 Statistics for WIBMesh and WIBNet

For advanced debugging of 915U-2, click Statistics on the home page of the Web-based configuration utility. This webpage details the state of the 915U-2 and provides performance information. This information is useful to ELPRO technical support personnel in diagnosing problems with the module. The WIBMesh and WIBNet Statistics pages are slightly different, but provide the same type of statistical information regarding the module and communications.



NOTE When updating the Statistics webpage, it is necessary to hold down the <CTRL> key while clicking the Refresh button. This ensures that your browser's cache is updated.

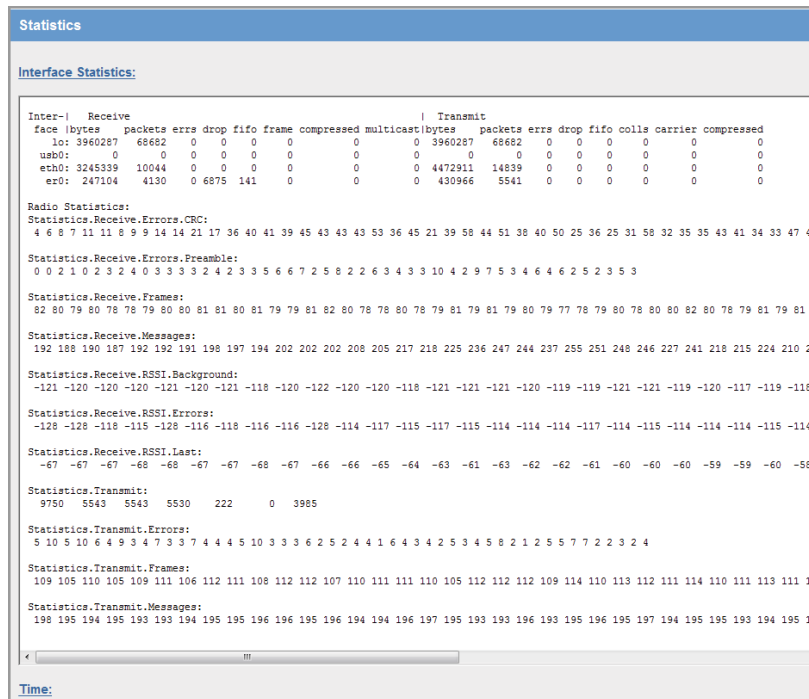

Figure 103 Module Statistics

CHAPTER 6 - SPECIFICATIONS

Specifications for the 915U-2 are provided in the following table.

Specifications	
Radio Transceiver	
Frequency	902–928 MHz ⁽¹⁾ ; 869.525 MHz; 869.875 MHz ⁽¹⁾
Transmit power	1 mW (+0 dBm) to 1W (+30 dBm) ⁽²⁾ 1 mW (+0 dBm) to 500 mW (+27 dBm) ⁽³⁾
Transmission	Frequency Hopping Spread Spectrum (FHSS) ⁽²⁾ Single Fixed Frequency ⁽³⁾
Modulation	Frequency Shift Keying (FSK)
Receive Sensitivity	–109 dBm @ 19.2 kbps (3% FER) ⁽²⁾ –109 dBm @ 14.4 kbps (3% FER) ⁽³⁾
Channel Spacing	50 x 250 kHz ^(2, 4) ; Single 250 kHz ^(2, 4)
Radio data rate	19.2–115.2 kbps ^(1, 2) ; 14.4–76.8 kbps ^(1, 3)
Range (LOS) Typically	32 km (20 mi) @ 1W ^(2,5) ; 10 km (6 mi) @ 500 mW ^(3,5)
Antenna Connector	1 x Female SMA Standard Polarity
Input/Output	
Discrete Input	8 Digital I/O (1–4 Configurable as Pulsed Input or Output) On-State Voltage: < 2.1 Vdc Wetting Current: 3.3 mA Max I/P Pulse Rate: DI 1/2: 50 kHz; DI 3/4: 1 kHz Max I/P Pulse Width: DI 1/2: 10 µsec; PI 3/4: 0.2 msec
Discrete Output	8 Digital I/O (1–4 Configurable as Pulsed Input or Output) On-State Voltage: DO Max, < 0.5V Maximum Current: 200 mA Max O/P Pulse Rate: PO Max Rate, 1 kHz
Analog Inputs	4 AI (2 Differential, 2 Single Ended) Current Range: 0–24 mA Current Resolution: 14 bits Accuracy (Current): 0.1% Voltage Input Range: AI 1/2: 0–20V, AI 3/4: 0–5V Voltage Resolution: 14 bits Accuracy (Voltage): 0.1% full scale
Analog Output	2 AO (Sourcing) Current Range: 0–24 mA Current Resolution: 13 bits Accuracy (Current): 0.1% (20 µA)
Ethernet Ports	
Ethernet Port	10/100baseT; RJ45 Connector, IEEE 802.3
Link Activity	Link, 100BaseT via LED
Serial Ports	
RS-232 Port	EIA-562 (RJ45 Connector)
RS-485 Port	2-Pin Terminal Block, Non-isolated ⁽⁶⁾
Data Rate (Bps)	1200, 2400, 4800, 9600, 14400, 19200, 38400, 57600, 76800, 115200, 230400 bps
Serial Settings	7 / 8 Data Bits; Stop/Start/Parity (Configurable)

Specifications	
Protocols and Configuration	
System Address	ESSID; 1–31 Character Text String
Protocols Supported	TCP/IP, UDP, HTTP, FTP, TFTP, Telnet, Modbus RTU Master/Slave, Modbus-TCP Client/Server
User Configuration	All User Configurable Parameters via HTTPS
Configurable Parameters	Unit details, I/O mappings and parameters, radio settings. For configuration details, see Chapter 4 in this manual. Modbus TCP/ RTU Gateway Embedded Modbus Master/Slave for I/O Transfer
Security	Data Encryption: 256bit AES, Secure HTTP Protocol
LED Indication/Diagnostics	
LED Indication	Power/OK; TX/RX; RS-232; RS-485; Digital I/O; Analog I/O Status
Reported Diagnostics	RSSI Measurements (dBm), Connectivity Information/Statistics, System Log File
Network Management	Optional Network Management System
Compliance	
EMC	FCC Part 15; EN 301 489; AS 3548
RF (Radio)	FCC Part 15.247; AS 4268.2 ; RFS29 NZ
Hazardous Area	CSA Class I, Division 2; ATEX; IECEx ec IIC T4 Gc
Safety	IEC 60950 (RoHS Compliant)
UL	UL Listed
General	
Size	180 x 150 x 35 mm (5.91" x 7.09" x 1.38")
Housing	IP20 Rated High Density Thermoplastic
Mounting	DIN Rail
Terminal Blocks	Removable; Max Conductor 12 AWG (2.5 mm ²)
Temperature Rating	–40 to +60°C; –40 to +140°F
Humidity Rating	0–99% RH Non-condensing
Weight	0.5 kg (1.1 lb).
Power Supply	
Nominal Supply	10.8 to 30 Vdc; Under/Over Voltage Protection
Average Current Draw	220 mA @ 12V (Idle), 110 mA @ 24V (Idle)
Transmit Current Draw	500 mA @ 12V (1W), 250 mA @ 24V (1W)
<p>NOTE Specifications subject to change.</p> <ol style="list-style-type: none"> 1) Country specific configuration (specified at time of order). 2) 900 MHz ISM Band. 3) 869 MHz ISM Band (Europe). 4) 18 Channels (New Zealand). 5) Typical Maximum Line-of-sight Range. 6) Maximum Distance 1200m (3937 ft). 	

APENDIX A - DBM TO MW CONVERSION

Watts	dBm	Watts	dBm
10 mW	10 dBm	200 mW	23 dBm
13 mW	11 dBm	316 mW	25 dBm
16 mW	12 dBm	398 mW	26 dBm
20 mW	13 dBm	500 mW	27 dBm
25 mW	14 dBm	630 mW	28 dBm
32 mW	15 dBm	800 mW	29 dBm
40 mW	16 dBm	1.0 W	30 dBm
50 mW	17 dBm	1.3 W	31 dBm
63 mW	18 dBm	1.6 W	32 dBm
80 mW	19 dBm	2.0 W	33 dBm
100 mW	20 dBm	2.5 W	34 dBm
126 mW	21 dBm	3.2 W	35 dBm
158 mW	22 dBm	4.0 W	36 dBm

APPENDIX B - I/O STORE REGISTERS

Output Coils

Output Coils	Description
0001 0008	Local DIO1–DIO8 as digital outputs
0009 0020	Spare
0021 0500	Space for locally attached 115s expansion I/O modules. Twenty register per module address, maximum number of modules is 24. For details, see Appendix C.
0501 3000	General purpose bit storage used for: <ul style="list-style-type: none"> • Staging area for data concentrator • Fieldbus mappings storage • Force mapping registers (see “Startup or Force Configuration” on page 45)
3001 10000	Not available

Input Bits

Input Bits	Description
10001 10008	Local DIO1–DIO8 as digital inputs
10009 10020	Set point status from analog inputs 1 through 12
10021 10500	Space for locally attached 115s expansion I/O modules. Twenty registers per module address, maximum number of modules is 24. For details, see Appendix C.
10501 10595	WIBMesh: general purpose bit storage and staging area for data concentrator fieldbus mappings storage. WIBNet: Remote Comms Fail indication. Corresponds to unit address (for example, remote address 1–95).
10596 12500	Continuation of general purpose bit storage. Staging area for data concentrator fieldbus mappings storage.
12501 30000	Not available

Input Registers

Input Registers	Description
30001 30004	Local AI1–AI4 (analog inputs, current mode) AI1 and AI2: 4–20 mA differential AI3 and AI4: 4–20 mA sink
30005 30006 30007 30008	Local supply voltage (0–40V scaling) Local 24V loop voltage (0–40V scaling) Local battery voltage (0–40V scaling) 115S supply voltage (0–40V scaling)
30009	Local AI1–AI4, (analog inputs, voltage mode)
30012	AI1 and AI2: 0–20V AI3 and AI4: 0–5V
30013 30016	Local pulse input rates: PI1–PI4
30018 30020	Spare

Input Registers	Description
30021 30493	Space for locally attached 115s expansion I/O modules. Twenty registers per module address, maximum number of modules is 24. For details, see Appendix C.
30494 30500	Internal information registers: serial number, firmware version and patch level
30501 32500	General purpose word storage used for: <ul style="list-style-type: none"> • Staging area for data concentrator • Fieldbus mappings storage
32501 36000	Not available
36001 36008	Local pulsed inputs 1–4, big endian format Most significant word at lower/odd address
36009 36040	Spare
36041 38000	Not available
38001 38032	Local analog inputs as floating point values ModScan format (sign + exponent + most significant 7 bits of significand at even/higher addressed location; lower 16 bits of significand at lower/odd addressed location) (12.3 => 38001=CCCD, 38002=4144)
38033–38040	Spare space for floating point values

Holding Registers

Holding Registers	Description
40001 40002	Local AO1 and AO2: analog outputs
40003 40020	Spare
40021 40500	Space for locally attached 115s expansion I/O modules. Twenty registers per module address, maximum number of modules is 24. For details, see Appendix C.
40501 42500	General purpose word storage area used for: <ul style="list-style-type: none"> • Staging area for data concentrator • Fieldbus mappings storage
42501 46000	Not available
46001 46008	Local pulsed outputs 1–4 Big endian format Most significant word at lower/odd address
46009 46040	Spare 32 bit registers
46041 48000	Not available
48001 48004	Local analog outputs as floating point values ModScan format (sign + exponent + most significant 7 bits of significand at even/higher addressed location) Lower 16 bits of significand at lower/odd addressed location (12.3 => 48001=0xCCCD, 48002=0x4144)
48005 48040	Spare space for floating point values
48041 onwards	Not available

APPENDIX C - EXPANSION I/O REGISTERS

Adding expansion I/O modules to the 915U-2 will automatically add the I/O from the 115S modules to the internal 915U-2 I/O store. To calculate the register location in the I/O store, find the address of the I/O point in the tables in this appendix, and then add the offset. The offset is the Modbus address, multiplied by 20.

Examples:

- Digital input #1 on an 115S-11 with address 5 would be: $(5 \times 20) + 10001 = 10101$
- Digital output #2 on an 115S-11 with address 6 would be: $(6 \times 20) + 2 = 122$
- Analog input #3 on an 115S-12 with address 3 would be: $(3 \times 20) + 30003 = 30063$.
- Analog output #8 on an 115S-13 with address # 7 would be: $(7 \times 20) + 40007 = 40147$

I/O Store for 115S-11 Expansion I/O Modules

I/O Store	Description
0001 + Offset 0016 + Offset	DIO outputs 1–16
10001 + Offset 10016 + Offset	DIO inputs 1–16
10019 + Offset	Modbus Comms Fail indication for this 115S module
10020 + Offset	Modbus Comms Fail indication (inverse) for this 115S module
30001 + Offset 30004 + Offset	115S-11 pulsed input rate 1–4
30005 + Offset 30012 + Offset	115S-11 pulsed input count
30017 + Offset	Modbus Error counter for this 115S module
30018 + Offset	Modbus Last Error code for this 115S module (see “Expansion I/O Error Registers” on page 81.)
30019 + Offset	Modbus Lost Link counter for this 115S module
30020 + Offset	Module type (0x0101) = 257 / error status
40009 + Offset 40016 + Offset	Pulsed output target 1–8 (1 register per pulsed output)

I/O Store for 115S-12 Expansion I/O Modules

I/O Store	Description
0001 + Offset 0008 + Offset	DIO outputs 1–8
10001 + Offset 10008 + Offset	DIO Inputs 1–8
10019 + Offset	Modbus Error indication for 115S module
10020 + Offset	Detected indication for this 115S module
30001 + Offset 30008 + Offset	Inputs AIN 1–AIN 8
30017 + Offset	Modbus Error counter for this 115S module
30018 + Offset	Modbus Last Error code for this 115S module (see “Expansion I/O Error Registers” on page 81)
30019 + Offset	Modbus Lost Link counter for this 115S module
30020 + Offset	Module type (0x0201) = 513 / error status
40009 + Offset 40016 + Offset	Pulsed output target 1–8 (1 register per output)

I/O Store for 115S-13 Expansion I/O Modules

I/O Store	Description
0001 + Offset 0008 + Offset	DIO outputs 1–8
10001 + Offset 10008 + Offset	DIO inputs 1–8
10019 + Offset	Modbus Error indication for 115S module
10020 + Offset	Detected indication for this 115S module
30017 + Offset	Modbus Error counter for this 115S module
30018 + Offset	Modbus Last Error code for this 115S module (see “Expansion I/O Error Registers” on page 81)
30019 + Offset	Modbus Lost Link counter for this 115S module
30020 + Offset	Module type (0x0301) = 769 / error status
40001 + Offset 40008 + Offset	Analog output 1–8
40009 + Offset 40016 + Offset	Pulsed output target 1–8 (one register per pulsed output)

APPENDIX D - MODBUS ERROR CODES

The following are Modbus error response codes that the Master will generate and write to a general purpose analog register (30501, 40501, and so on) in the event of a poll fail.

Dec Code	Hex Code	Name	Meaning
65281	FF01	Illegal Function	The function code received in the query is not an allowable action for the server (or slave). This may be because the function code is only applicable to newer devices, and was not implemented in the unit selected. It might also indicate that the server (or slave) is in the wrong state to process a request of this type.
65282	FF02	Illegal Data Address	The data address received in the query is not an allowable address for the server (or slave). More specifically, the combination of reference number and transfer length is invalid. For a controller with 100 registers, the PDU addresses the first register as 0, and the last one as 99. If a request is submitted with a starting register address of 96 and a quantity of 4 registers, this request will successfully operate on registers 96, 97, 98, 99. If a request is submitted with a starting register address of 96 and a quantity of 5, this request will fail with Exception Code 0x02 "Illegal Data Address."
65283	FF03	Illegal Data Value	A value contained in the query data field is not an allowable value for server (or slave). This indicates a fault in the structure of the remainder of a complex request. For example, it may indicate that the implied length is incorrect. It does not mean that a data item submitted for storage in a register has a value outside the expectation of the application program. The Modbus protocol is unaware of the significance of any particular value of any particular register.
65384	FF04	Slave Device Failure	An unrecoverable error occurred while the server (or slave) was attempting to perform the requested action.
65285	FF05	Acknowledge	Specialized use in conjunction with programming commands. The server (or slave) has accepted the request and is processing it, but significant time will be required to complete this task. This response is returned to prevent a timeout error from occurring in the client (or master).
65286	FF06	Slave Device Busy	Specialized use in conjunction with programming commands. The server (or slave) is engaged in processing a long-duration program command. The client (or master) should retransmit the message later when the server (or slave) is free.
65288	FF08	Memory Parity Error	Specialized use in conjunction with function codes 20 and 21 and reference type 6, to indicate that the extended file area failed to pass a consistency check.
65290	FF0A	Gateway Path Unavailable	Specialized use in conjunction with gateways. Indicates that the gateway was unable to allocate an internal communication path from the input port to the output port for processing the request. Typically indicates that the gateway is mis-configured or overloaded.
65291	FF0B	Gateway Device Failed to Respond	Specialized use in conjunction with gateways. Indicates that no response was obtained from the target device. Typically indicates that the device is not present on the network.
65024	FE00	Invalid Response from Slave	Command type or slave address did not match request (probably another unit).
64512	FC00	Server Offline	Could not connect to the Modbus TCP server.
63488	F800	Invalid Local Memory Address	Local address is invalid in the command. The memory location does not exist or is not initialized.
65535	FFFF	No Response to the Poll	There was no response to the poll message.

APPENDIX E - PHYSICAL I/O REGISTERS

I/O	Input	Output
Digital I/O 1	10001	1
Digital I/O 2	10002	2
Digital I/O 3	10003	3
Digital I/O 4	10004	4
Digital I/O 5	10005	5
Digital I/O 6	10006	6
Digital I/O 7	10007	7
Digital I/O 8	10008	8
Analog Input 1 (mA)	30001	
Analog Input 2 (mA)	30002	
Analog Input 3 (mA)	30003	
Analog Input 4 (mA)	30004	
Input 5 – Local V Supply	30005	
Input 6 – Local +24V Analog Loop	30006	
Input 7 – Local V Battery	30007	
Input 8 – Local V Expansion I/O	30008	
Analog Input 1 (Volts)	30009	
Analog Input 2 (Volts)	30010	
Analog Input 3 (Volts)	30011	
Analog Input 4 (Volts)	30012	
Pulse Rate 1	30013	
Pulse Rate 2	30014	
Pulse Rate 3	30015	
Pulse Rate 4	30016	
Analog 1 Set point	10009	
Analog 2 Set point	10010	
Analog 3 Set point	10011	
Analog 4 Set point	10012	
Analog 5 Set point	10013	
Analog 6 Set point	10014	
Analog 7 Set point	10015	
Analog 8 Set point	10016	
Analog 9 Set point	10017	
Analog 10 Set point	10018	
Analog 11 Set point	10019	
Analog 12 Set point	10020	
Analog Output 1		40001
Analog Output 2		40002
Pulsed Input 1 Count	36001-36002	
Pulsed Input 2 Count	36003-36004	
Pulsed Input 3 Count	36005-36006	
Pulsed Input 4 Count	36007-36008	
Pulsed Input 1 Rate	30013	

I/O	Input	Output
Pulsed Input 2 Rate	30014	
Pulsed Input 3 Rate	30015	
Pulsed Input 4 Rate	30016	
Pulsed Output 1 Count		46001-46002
Pulsed Output 2 Count		46003-46004
Pulsed Output 3 Count		46005-46006
Pulsed Output 4 Count		46007-46008
Analog Input 1 Floating Point (mA)	38001-38002	
Analog Input 2 Floating Point (mA)	38003-38004	
Analog Input 3 Floating Point (mA)	38005-38006	
Analog Input 4 Floating Point (mA)	38007-38008	
Input 5 – Local V Supply Floating Point	38009-38010	
Input 6 – Local +24V Analog Loop Floating Point	38011-38012	
Input 7 – Local V Battery Floating Point	38013-38014	
Input 8 – Local V Expansion I/O Floating Point	38015-38016	
Analog Input 1 Floating Point (Volts)	38017-38018	
Analog Input 2 Floating Point (Volts)	38019-38020	
Analog Input 3 Floating Point (Volts)	38021-38022	
Analog Input 4 Floating Point (Volts)	38023-38024	
Pulse Rate 1 Floating Point	38025-38026	
Pulse Rate 2 Floating Point	38027-38028	
Pulse Rate 3 Floating Point	38029-38030	
Pulse Rate 4 Floating Point	38031-38032	
Analog O/P Floating Point		48001
Analog O/P Floating Point		48002
Analog O/P Floating Point		48003
Analog O/P Floating Point		48004

115S Serial Expansion Modules I/O Registers

Description	115S-11		115S-12		115S-13	
	Inputs	Outputs	Inputs	Outputs	Inputs	Outputs
Digital I/O 1	10001	1	10001	1	10001	1
Digital I/O 2	10002	2	10002	2	10002	2
Digital I/O 3	10003	3	10003	3	10003	3
Digital I/O 4	10004	4	10004	4	10004	4
Digital I/O 5	10005	5	10005	5	10005	5
Digital I/O 6	10006	6	10006	6	10006	6
Digital I/O 7	10007	7	10007	7	10007	7
Digital I/O 8	10008	8	10008	8	10008	8
Digital I/O 9	10009	9				
Digital I/O 10	10010	10				
Digital I/O 11	10011	11				
Digital I/O 12	10012	12				
Digital I/O 13	10013	13				
Digital I/O 14	10014	14				

ELPRO 915U-2 Wireless Mesh I/O and Gateway User Manual

Description	115S-11		115S-12		115S-13	
	Inputs	Outputs	Inputs	Outputs	Inputs	Outputs
Digital I/O 15	10015	15				
Digital I/O 16	10016	16				
Analog I/O 1			30001			40001
Analog I/O 2			30002			40002
Analog I/O 3			30003			40003
Analog I/O 4			30004			40004
Analog I/O 5			30005			40005
Analog I/O 6			30006			40006
Analog I/O 7			30007			40007
Analog I/O 8			30008			40008
Pulsed I/O Count 1	30017-30018	40009		40009		40009
Pulsed I/O Count 2	30019-30020	40010		40010		40010
Pulsed I/O Count 3	30020-30022	40011		40011		40011
Pulsed I/O Count 4	30023-30024	40012		40012		40012
Pulsed I/O Count 5		40013		40013		40013
Pulsed I/O Count 6		40014		40014		40014
Pulsed I/O Count 7		40015		40015		40015
Pulsed I/O Count 8		40016		40016		40016
Pulsed I/O Rate 1	30001					
Pulsed I/O Rate 2	30002					
Pulsed I/O Rate 3	30003					
Pulsed I/O Rate 4	30004					
Supply Voltage	30033		30033		30033	
Analog Loop Supply	30034		30034		30034	

All expansion I/O is calculated by adding the offset to the I/O address in the table. The offset is calculated by multiplying the module address by 20.

For example:

- Digital input #1 on an 115S-11 (address 5) would be: $(5 \times 20) + 10001 = 10100$
- Digital output #2 on an 115S-11 (address 6) would be: $(6 \times 20) + 2 = 121$
- Analog input #3 on an 115S-12 (address 3) would be: $(3 \times 20) + 30003 = 30063$
- Analog output #7 on an 115S-13 (address 7) would be: $(7 \times 20) + 40007 = 40147$

APPENDIX F - GNU FREE DOCUMENT LICENSE

Version 2, June 1991

Copyright (C) 1989, 1991 Free Software Foundation, Inc.

51 Franklin Street, Fifth Floor, Boston, MA 02110-1301, USA

Everyone is permitted to copy and distribute verbatim copies of this license document, but changing it is not allowed.

Preamble

The licenses for most software are designed to take away your freedom to share and change it. By contrast, the GNU General Public License is intended to guarantee your freedom to share and change free software--to make sure the software is free for all its users. This General Public License applies to most of the Free Software Foundation's software and to any other program whose authors commit to using it. (Some other Free Software Foundation software is covered by the GNU Lesser General Public License instead.) You can apply it to your programs, too.

When we speak of free software, we are referring to freedom, not price. Our General Public Licenses are designed to make sure that you have the freedom to distribute copies of free software (and charge for this service if you wish), that you receive source code or can get it if you want it, that you can change the software or use pieces of it in new free programs; and that you know you can do these things.

To protect your rights, we need to make restrictions that forbid anyone to deny you these rights or to ask you to surrender the rights. These restrictions translate to certain responsibilities for you if you distribute copies of the software, or if you modify it.

For example, if you distribute copies of such a program, whether gratis or for a fee, you must give the recipients all the rights that you have. You must make sure that they, too, receive or can get the source code. And you must show them these terms so they know their rights.

We protect your rights with two steps: (1) copyright the software, and (2) offer you this license which gives you legal permission to copy, distribute and/or modify the software.

Also, for each author's protection and ours, we want to make certain that everyone understands that there is no warranty for this free software. If the software is modified by someone else and passed on, we want its recipients to know that what they have is not the original, so that any problems introduced by others will not reflect on the original authors' reputations.

Finally, any free program is threatened constantly by software patents. We wish to avoid the danger that redistributors of a free program will individually obtain patent licenses, in effect making the program proprietary. To prevent this, we have made it clear that any patent must be licensed for everyone's free use or not licensed at all.

The precise terms and conditions for copying, distribution and modification follow.

Terms And Conditions For Copying, Distribution And Modification

This License applies to any program or other work which contains a notice placed by the copyright holder saying it may be distributed under the terms of this General Public License. The "Program", below, refers to any such program or work, and a "work based on the Program" means either the Program or any derivative work under copyright law: that is to say, a work containing the Program or a portion of it, either verbatim or with modifications and/or translated into another language. (Hereinafter, translation is included without limitation in the term "modification".) Each licensee is addressed as "you".

Activities other than copying, distribution and modification are not covered by this License; they are outside its scope. The act of running the Program is not restricted, and the output from the Program is covered only if its contents constitute a work based on the Program (independent of having been made by running the Program). Whether that is true depends on what the Program does.

1. You may copy and distribute verbatim copies of the Program's source code as you receive it, in any medium, provided that you conspicuously and appropriately publish on each copy an appropriate copyright notice and

disclaimer of warranty; keep intact all the notices that refer to this License and to the absence of any warranty; and give any other recipients of the Program a copy of this License along with the Program.

You may charge a fee for the physical act of transferring a copy, and you may at your option offer warranty protection in exchange for a fee.

2. You may modify your copy or copies of the Program or any portion of it, thus forming a work based on the Program, and copy and distribute such modifications or work under the terms of Section 1 above, provided that you also meet all of these conditions:
 - a. You must cause the modified files to carry prominent notices stating that you changed the files and the date of any change.
 - b. You must cause any work that you distribute or publish, that in whole or in part contains or is derived from the Program or any part thereof, to be licensed as a whole at no charge to all third parties under the terms of this License.
 - c. If the modified program normally reads commands interactively when run, you must cause it, when started running for such interactive use in the most ordinary way, to print or display an announcement including an appropriate copyright notice and a notice that there is no warranty (or else, saying that you provide a warranty) and that users may redistribute the program under these conditions, and telling the user how to view a copy of this License. (Exception: if the Program itself is interactive but does not normally print such an announcement, your work based on the Program is not required to print an announcement.)

These requirements apply to the modified work as a whole. If identifiable sections of that work are not derived from the Program, and can be reasonably considered independent and separate works in themselves, then this License, and its terms, do not apply to those sections when you distribute them as separate works. But when you distribute the same sections as part of a whole which is a work based on the Program, the distribution of the whole must be on the terms of this License, whose permissions for other licensees extend to the entire whole, and thus to each and every part regardless of who wrote it.

Thus, it is not the intent of this section to claim rights or contest your rights to work written entirely by you; rather, the intent is to exercise the right to control the distribution of derivative or collective works based on the Program.

In addition, mere aggregation of another work not based on the Program with the Program (or with a work based on the Program) on a volume of a storage or distribution medium does not bring the other work under the scope of this License.

3. You may copy and distribute the Program (or a work based on it, under Section 2) in object code or executable form under the terms of Sections 1 and 2 above provided that you also do one of the following:
 - a. Accompany it with the complete corresponding machine-readable source code, which must be distributed under the terms of Sections 1 and 2 above on a medium customarily used for software interchange; or,
 - b. Accompany it with a written offer, valid for at least three years, to give any third party, for a charge no more than your cost of physically performing source distribution, a complete machine-readable copy of the corresponding source code, to be distributed under the terms of Sections 1 and 2 above on a medium customarily used for software interchange; or,
 - c. Accompany it with the information you received as to the offer to distribute corresponding source code. (This alternative is allowed only for noncommercial distribution and only if you received the program in object code or executable form with such an offer, in accord with Subsection b above.)

The source code for a work means the preferred form of the work for making modifications to it. For an executable work, complete source code means all the source code for all modules it contains, plus any associated interface definition files, plus the scripts used to control compilation and installation of the executable. However, as a special exception, the source code distributed need not include anything that is normally distributed (in either source or binary form) with the major components (compiler, kernel, and so on) of the operating system on which the executable runs, unless that component itself accompanies the executable.

If distribution of executable or object code is made by offering access to copy from a designated place, then offering equivalent access to copy the source code from the same place counts as distribution of the source code, even though third parties are not compelled to copy the source along with the object code.

4. You may not copy, modify, sublicense, or distribute the Program except as expressly provided under this License. Any attempt otherwise to copy, modify, sublicense or distribute the Program is void, and will automatically terminate your rights under this License. However, parties who have received copies, or rights, from you under this License will not have their licenses terminated so long as such parties remain in full compliance.
5. You are not required to accept this License, since you have not signed it. However, nothing else grants you permission to modify or distribute the Program or its derivative works. These actions are prohibited by law if you do not accept this License. Therefore, by modifying or distributing the Program (or any work based on the Program), you indicate your acceptance of this License to do so, and all its terms and conditions for copying, distributing or modifying the Program or works based on it.
6. Each time you redistribute the Program (or any work based on the Program), the recipient automatically receives a license from the original licensor to copy, distribute or modify the Program subject to these terms and conditions. You may not impose any further restrictions on the recipients' exercise of the rights granted herein. You are not responsible for enforcing compliance by third parties to this License.
7. If, as a consequence of a court judgment or allegation of patent infringement or for any other reason (not limited to patent issues), conditions are imposed on you (whether by court order, agreement or otherwise) that contradict the conditions of this License, they do not excuse you from the conditions of this License. If you cannot distribute so as to satisfy simultaneously your obligations under this License and any other pertinent obligations, then as a consequence you may not distribute the Program at all. For example, if a patent license would not permit royalty-free redistribution of the Program by all those who receive copies directly or indirectly through you, then the only way you could satisfy both it and this License would be to refrain entirely from distribution of the Program.

If any portion of this section is held invalid or unenforceable under any particular circumstance, the balance of the section is intended to apply and the section as a whole is intended to apply in other circumstances.

It is not the purpose of this section to induce you to infringe any patents or other property right claims or to contest validity of any such claims; this section has the sole purpose of protecting the integrity of the free software distribution system, which is implemented by public license practices. Many people have made generous contributions to the wide range of software distributed through that system in reliance on consistent application of that system; it is up to the author/donor to decide if he or she is willing to distribute software through any other system and a licensee cannot impose that choice.

This section is intended to make thoroughly clear what is believed to be a consequence of the rest of this License.

8. If the distribution and/or use of the Program is restricted in certain countries either by patents or by copyrighted interfaces, the original copyright holder who places the Program under this License may add an explicit geographical distribution limitation excluding those countries, so that distribution is permitted only in or among countries not thus excluded. In such case, this License incorporates the limitation as if written in the body of this License.
9. The Free Software Foundation may publish revised and/or new versions of the General Public License from time to time. Such new versions will be similar in spirit to the present version, but may differ in detail to address new problems or concerns.

Each version is given a distinguishing version number. If the Program specifies a version number of this License which applies to it and "any later version", you have the option of following the terms and conditions either of that version or of any later version published by the Free Software Foundation. If the Program does not specify a version number of this License, you may choose any version ever published by the Free Software Foundation.

10. If you wish to incorporate parts of the Program into other free programs whose distribution conditions are different, write to the author to ask for permission. For software which is copyrighted by the Free Software

Foundation, write to the Free Software Foundation; we sometimes make exceptions for this. Our decision will be guided by the two goals of preserving the free status of all derivatives of our free software and of promoting the sharing and reuse of software generally.

NO WARRANTY

11. BECAUSE THE PROGRAM IS LICENSED FREE OF CHARGE, THERE IS NO WARRANTY FOR THE PROGRAM, TO THE EXTENT PERMITTED BY APPLICABLE LAW. EXCEPT WHEN OTHERWISE STATED IN WRITING THE COPYRIGHT HOLDERS AND/OR OTHER PARTIES PROVIDE THE PROGRAM "AS IS" WITHOUT WARRANTY OF ANY KIND, EITHER EXPRESSED OR IMPLIED, INCLUDING, BUT NOT LIMITED TO, THE IMPLIED WARRANTIES OF MERCHANTABILITY AND FITNESS FOR A PARTICULAR PURPOSE. THE ENTIRE RISK AS TO THE QUALITY AND PERFORMANCE OF THE PROGRAM IS WITH YOU. SHOULD THE PROGRAM PROVE DEFECTIVE, YOU ASSUME THE COST OF ALL NECESSARY SERVICING, REPAIR OR CORRECTION.
12. IN NO EVENT UNLESS REQUIRED BY APPLICABLE LAW OR AGREED TO IN WRITING WILL ANY COPYRIGHT HOLDER, OR ANY OTHER PARTY WHO MAY MODIFY AND/OR REDISTRIBUTE THE PROGRAM AS PERMITTED ABOVE, BE LIABLE TO YOU FOR DAMAGES, INCLUDING ANY GENERAL, SPECIAL, INCIDENTAL OR CONSEQUENTIAL DAMAGES ARISING OUT OF THE USE OR INABILITY TO USE THE PROGRAM (INCLUDING BUT NOT LIMITED TO LOSS OF DATA OR DATA BEING RENDERED INACCURATE OR LOSSES SUSTAINED BY YOU OR THIRD PARTIES OR A FAILURE OF THE PROGRAM TO OPERATE WITH ANY OTHER PROGRAMS), EVEN IF SUCH HOLDER OR OTHER PARTY HAS BEEN ADVISED OF THE POSSIBILITY OF SUCH DAMAGES.

APPENDIX G – OVER THE AIR CONFIGURATION

The WIBMesh 915U-2 modules communicate using standard Ethernet protocols, which makes it possible to connect to other 915U-2 modules within the radio network for over-the-air diagnostics and configuration changes. If you intend to use over-the-air configuration, planning is required when designing the system and some configuration settings need to be implemented in order for over-the-air programming to function.

Over-the-air configuration can only be performed from a central location. Often this location is a main hub (such as DCS or SCADA), but it can also be a module that is used only for over-the-air configuration and can be moved around within the system. Figure 104 shows an example of a small system set up with an over-the-air configuration. In this example, over-the-air configurations can only be performed using the PC connected to the Central 915U-2.

Over the air Configuration

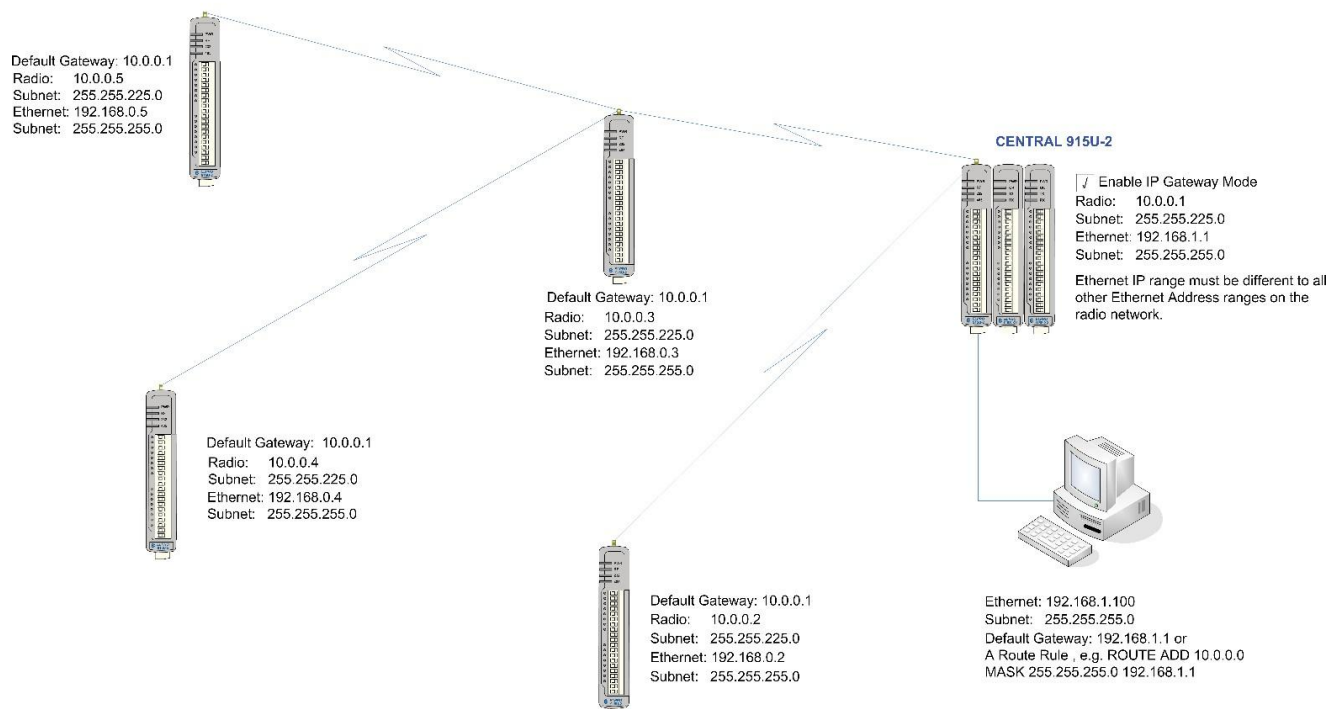

Figure 104 Over-the-air Configuration

Use the following procedure to set up the system for over-the-air configuration. Once the system is set up, it will allow configuration and diagnostics access to all remote modules from the PC connected to the module designated as the gateway module. The MConfig Utility can then be used to configure modules across the radio network.

Before you begin, make sure that all 915U-2 modules in the system have been added to the MConfig Utility. For details, see "Adding Units to a Project" on page 37.

1. Configure the 915U-2 module that will be used as the gateway for all over-the-air configurations:
 - a. In the MConfig project tree, click the module to be used as the gateway.
 - b. Select the IP Gateway Mode checkbox (see Figure 105).

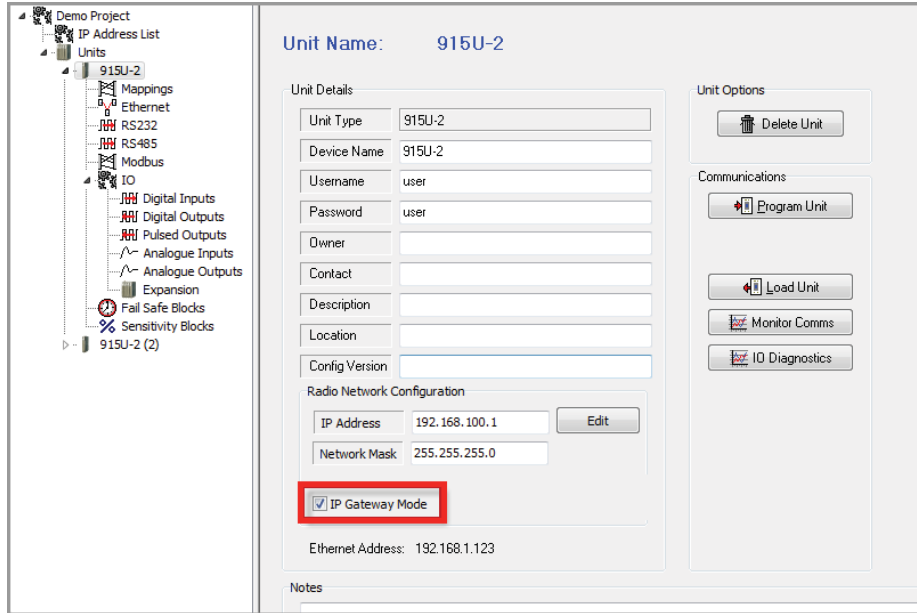

Figure 105 IP Gateway Mode

2. For each remote module, configure the default gateway address to point back to the radio IP address of the gateway module:
 - a. Click a remote module in the project tree, and then click Ethernet.
 - b. Select the Use Default Gateway checkbox and enter the radio IP address of the gateway module.

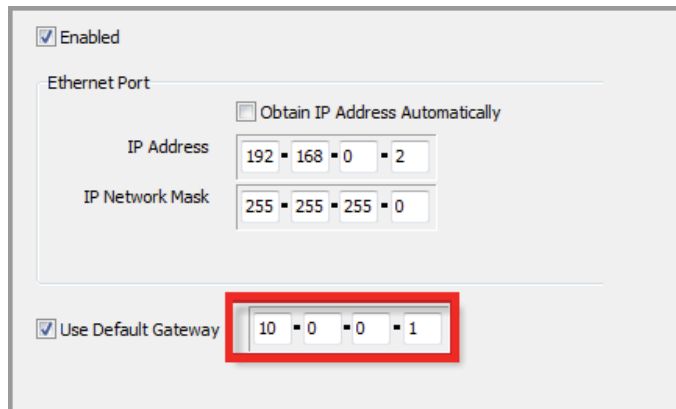

Figure 106 Default Gateway

- c. Make sure that the Ethernet IP network address of the remote module is either on a different subnet than the gateway module or disabled.

If the remote Ethernet ports are not used, they can all be configured with the same IP address or be disabled. Disabling them will mean that you can no longer access the module's configuration locally via Ethernet, and configuration can only be accessed via USB connection to the module. To disable Ethernet ports, deselect the "Enabled" checkbox.

Figure 107 IP Address Range

3. Configure the default gateway address on the PC to match the gateway module's Ethernet IP address, or add a routing rule to its default routing table.

To add a routing rule, choose Run from the Windows Start menu, and then type "Cmd" and press Enter. When the DOS window appears, type the route command. For example, ROUTE ADD 10.0.0.0 MASK 255.255.255.0 192.168.1.1, as shown in Figure 108.

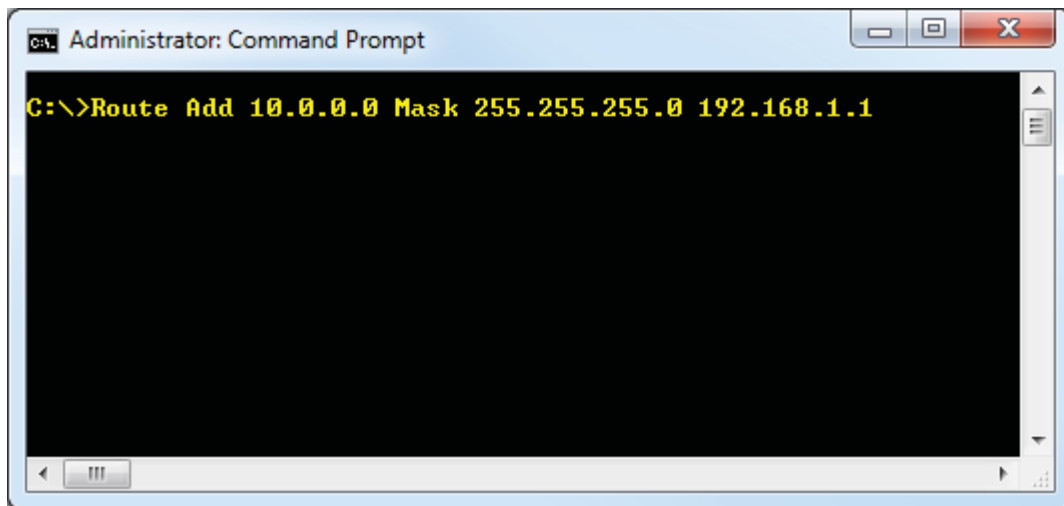

Figure 108 Adding a Route

If you want to be able to configure the system from any location, a special dedicated module must be setup and all configurations will needed to be performed through the dedicated module.

APPENDIX H - GLOSSARY

Term	Definition
ACK	Acknowledgment.
Access Point	An access point connects wireless network stations (or clients) to other stations within the wireless network and also can serve as the point of interconnection between the wireless network and a wired network. Each access point can serve multiple users within a defined network area. Also known as a base station.
Antenna Gain	Antennae do not increase the transmission power, but instead focus the signal. Rather than transmitting in every direction (including the sky and ground), antenna focus the signal either more horizontally or in one particular direction. This gain is measured in decibels.
AODV	Ad hoc On-Demand Distance Vector (AODV) Routing is a routing protocol for mobile ad hoc networks and other wireless ad hoc networks. In AODV, the network is silent until a connection is needed. At that point the network node that needs a connection broadcasts a request for connection. Other AODV nodes forward this message, and record the node that they heard it from, creating an explosion of temporary routes back to the needy node. When a node receives such a message and already has a route to the desired node, it sends a message backwards through a temporary route to the requesting node. The needy node then begins using the route that has the least number of hops through other nodes. Unused entries in the routing tables are recycled after a time.
AWG	American wire gauge (AWG), also known as the Brown & Sharpe wire gauge, is a standardized wire gauge system used predominantly in the United States and Canada for the diameters of round, solid, nonferrous, electrically conducting wire.
Bandwidth	The maximum data transfer speed available to a user through a network.
COS	Change of state. For a digital input, a COS is a change from "off" to "on," or a change from "on" to "off." For an analog input, internal analog input, or pulse input rate, a COS is a configurable value called sensitivity.
CSA	The Canadian Standards Association (CSA), is a not-for-profit standards organization that develops standards in 57 areas. The CSA registered mark shows that a product has been independently tested and certified to meet recognized standards for safety or performance.
DCS	A Distributed Control System (DCS) is a computerized control system used to control the production line in industry. The entire system of controllers is connected by networks for communication and monitoring.
DHCP	Dynamic Host Configuration Protocol is a utility that enables a server to dynamically assign IP addresses from a predefined list and limit their time of use so that they can be reassigned. Without DHCP, an IT manager would need to manually enter in all the IP addresses of all the computers on the network. When DHCP is used, whenever a computer logs onto the network, an IP address is automatically assigned to it.
DIO	Digital input/output.
DIN Rail	A DIN rail is a metal rail of a standard type widely used for mounting circuit breakers and industrial control equipment inside equipment racks.
DNS	Domain name service (DNS) is a program that translates URLs to IP addresses by accessing a database maintained on a collection of Internet servers. The program works behind the scenes to facilitate surfing the Web with alpha versus numeric addresses. A DNS server converts a name like mywebsite.com to a series of numbers like 107.22.55.26. Every website has its own specific IP address on the Internet.
Encryption Key	An alphanumeric (letters and/or numbers) series that enables data to be encrypted and then decrypted so it can be safely shared among members of a network. WEP uses an encryption key that automatically encrypts outgoing wireless data. On the receiving side, the same encryption key enables the computer to automatically decrypt the information so it can be read. Encryption keys should be kept secret.

Term	Definition
EIRP	Equivalent isotropically radiated power (EIRP) or, alternatively, effective isotropically radiated power is the amount of power that a theoretical isotropic antenna (which evenly distributes power in all directions) would emit to produce the peak power density observed in the direction of maximum antenna gain. EIRP can take into account the losses in transmission line and connectors and includes the gain of the antenna. The EIRP is often stated in terms of decibels over a reference power emitted by an isotropic radiator with an equivalent signal strength. The EIRP allows comparisons between different emitters regardless of type, size or form.
Hub	A multiport device used to connect PCs to a network via Ethernet cabling or via 802.11. Wired hubs can have numerous ports and can transmit data at speeds ranging from 10 Mbps to multi-Gigabyte speeds per second. A hub transmits packets it receives to all the connected ports. A small wired hub may only connect four computers; a large hub can connect 48 or more.
Hz	Hertz. The international unit for measuring frequency, equivalent to the older unit of cycles per second. One megahertz (MHz) is one million hertz. One gigahertz (GHz) is one billion hertz. The standard US electrical power frequency is 60 Hz, the AM broadcast radio frequency band is 535–1605 kHz, the FM broadcast radio frequency band is 88–108 MHz, and wireless 802.11b/g LANs operate at 2.4 GHz.
IEEE	Institute of Electrical and Electronics Engineers, New York, www.ieee.org . A membership organization that includes engineers, scientists and students in electronics and allied fields. It has more than 300,000 members and is involved with setting standards for computers and communications.
I/O	Input/Output. The term used to describe any operation, program, or device that transfers data to or from a computer.
IP	Internet Protocol (IP) is a set of rules used to send and receive messages across local networks and the Internet.
IP Address	A 32-bit number that identifies each sender or receiver of information that is sent across the Internet. An IP address has two parts: an identifier of a particular network on the Internet and an identifier of the particular device (which can be a server or a workstation) within that network.
ISM	The industrial, scientific and medical (ISM) radio bands are portions of the radio spectrum reserved internationally for industrial, scientific, and medical purposes other than telecommunications.
LAN	Local Area Network (LAN) is a system of connecting PCs and other devices within the same physical proximity for sharing resources such as an Internet connections, printers, files, and drives.
LQI	Link quality indicator (LQI) is used in wireless networks to indicate how strong the communications link is. LQI is a computed value, based on the received signal strength as well as the number of errors received.
Receive Sensitivity	The minimum signal strength required to pick up a signal. Higher bandwidth connections usually have less receive sensitivity than lower bandwidth connections.
Router	A device that forwards data from one WLAN or wired local area network to another.
RSSI	Received signal strength indicator (RSSI) is a measurement of the power present in a received radio signal. In an IEEE 802.11 system, RSSI is the relative received signal strength in a wireless environment, in arbitrary units. RSSI is an indication of the power level being received by the antenna. Therefore, the higher the RSSI number (or less negative in some devices), the stronger the signal.
Transmit Power	The power at which the wireless devices transmits, usually expressed in mW or dBm.

Term	Definition
MAC Address	<p>Media Access Control (MAC) address is a unique code assigned to most forms of networking hardware. The address is permanently assigned to the hardware, so limiting a wireless network's access to hardware (such as wireless cards) is a security feature employed by closed wireless networks. But an experienced hacker armed with the proper tools can still figure out an authorized MAC address, masquerade as a legitimate address, and access a closed network.</p> <p>Every wireless 802.11 device has its own specific MAC address hard-coded into it. This unique identifier can be used to provide security for wireless networks. When a network uses a MAC table, only the 802.11 radios that have had their MAC addresses added to that network's MAC table will be able to get onto the network.</p>
Modbus	<p>Modbus is a serial communications protocol for use with its programmable logic controllers (PLCs).</p>
PLC	<p>A programmable logic controller (PLC) is a digital computer used for automation of electromechanical processes, such as control of machinery on factory assembly lines, amusement rides, or light fixtures.</p>
Proxy Server	<p>Used in larger companies and organizations to improve network operations and security, a proxy server is able to prevent direct communication between two or more networks. The proxy server forwards allowable data requests to remote servers and/or responds to data requests directly from stored remote server data.</p>
RJ-45	<p>Standard connectors used in Ethernet networks. RJ-45 connectors are similar to standard RJ-11 telephone connectors, but RJ-45 connectors can have up to eight wires, whereas telephone connectors have four.</p>
RTU	<p>A remote terminal unit (RTU) is a microprocessor-controlled electronic device that interfaces objects in the physical world to a distributed control system or SCADA system by transmitting telemetry data to a master system, and by using messages from the master supervisory system to control connected objects.</p>
SCADA	<p>SCADA (supervisory control and data acquisition) is a type of industrial control system (ICS). Industrial control systems are computer controlled systems that monitor and control industrial processes that exist in the physical world. SCADA systems historically distinguish themselves from other ICS systems by being large scale processes that can include multiple sites, and large distances.</p>
Server	<p>A computer that provides its resources to other computers and devices on a network. These include print servers, Internet servers and data servers. A server can also be combined with a hub or router.</p>
SMA	<p>SMA (SubMiniature version A) connectors are semi-precision coaxial RF connectors for coaxial cable with a screw type coupling mechanism. The connector has a 50Ω impedance. It is designed for use from DC to 18 GHz.</p>
Sub Network or Subnet	<p>Found in larger networks, these smaller networks are used to simplify addressing between numerous computers. Subnets connect together through a router.</p>
Switch	<p>A type of hub that efficiently controls the way multiple devices use the same network so that each can operate at optimal performance. A switch acts as a networks traffic cop: rather than transmitting all the packets it receives to all ports as a hub does, a switch transmits packets to only the receiving port.</p>
TCP	<p>Transmission Control Protocol (TCP) is protocol used along with the Internet Protocol (IP) to send data in the form of individual units (called packets) between computers over the Internet. While IP takes care of handling the actual delivery of the data, TCP takes care of keeping track of the packets that a message is divided into for efficient routing through the Internet. For example, when a webpage is downloaded from a Web server, the TCP program layer in that server divides the file into packets, numbers the packets, and then forwards them individually to the IP program layer. Although each packet has the same destination IP address, it may get routed differently through the network. At the other end, TCP reassembles the individual packets and waits until they have all arrived to forward them as single message.</p>

Term	Definition
TCP/IP	The underlying technology behind the Internet and communications between computers in a network. The first part, TCP, is the transport part, which matches the size of the messages on either end and guarantees that the correct message has been received. The IP part is the user's computer address on a network. Every computer in a TCP/IP network has its own IP address that is either dynamically assigned at startup or permanently assigned. All TCP/IP messages contain the address of the destination network as well as the address of the destination station. This enables TCP/IP messages to be transmitted to multiple networks (subnets) within an organization or worldwide.
TTL	Transistor–transistor logic (TTL) is a class of digital circuits built from bipolar junction transistors and resistors. It is called TTL logic because both the logic gating function (AND) and the amplifying function are performed by transistors.
WAN	Wide area network (WAN) is a communication system of connecting PCs and other computing devices across a large local, regional, national or international geographic area. Also used to distinguish between phone-based data networks and Wi-Fi. Phone networks are considered WANs and Wi-Fi networks are considered Wireless Local Area Networks (WLANs).
WEP	Wired Equivalent Privacy (WEP) is a basic wireless security provided by Wi-Fi. In some instances, WEP may be all a home or small-business user needs to protect wireless data. WEP is available in 40-bit (also called 64-bit), or in 108-bit (also called 128-bit) encryption modes. As 108-bit encryption provides a longer algorithm that takes longer to decode, it can provide better security than basic 40-bit (64-bit) encryption.
Wi-Fi	Wireless Fidelity. An interoperability certification for wireless local area network (LAN) products based on the Institute of Electrical and Electronics Engineers (IEEE) 802.11 standard.

Your Local Authorized ELPRO Technologies Distributor is:

